



九齊科技股份有限公司
Nyquest Technology Co., Ltd.

DATA SHEET

NY5B Series

**Single-Chip 4-bit MCU with 15 I/O
& 4-Ch Speech/Midi**

Version 1.3

Jul. 22, 2020

NYQUEST TECHNOLOGY CO. reserves the right to change this document without prior notice. Information provided by NYQUEST is believed to be accurate and reliable. However, NYQUEST makes no warranty for any errors which may appear in this document. Contact NYQUEST to obtain the latest version of device specifications before placing your orders. No responsibility is assumed by NYQUEST for any infringement of patent or other rights of third parties which may result from its use. In addition, NYQUEST products are not authorized for use as critical components in life support devices/systems or aviation devices/systems, where a malfunction or failure of the product may reasonably be expected to result in significant injury to the user, without the express written approval of NYQUEST.

Revision History

| <i>Version</i> | <i>Date</i> | <i>Description</i> | <i>Modified Page</i> |
|----------------|-------------|--|----------------------|
| 1.0 | 2012/10/31 | Formally release. | - |
| 1.1 | 2019/11/21 | Add NY5B035C, NY5B045C. | 3, 5, 7, 11, 15 |
| 1.2 | 2020/03/20 | Add NY5B(C) and remove corresponding (B) version. | 3~6 |
| 1.3 | 2020/07/22 | <ol style="list-style-type: none">1. Add NY5B046C, remove NY5B045C2. Update the Voltage vs Frequency figures. | 3~7, 11, 15 12 |

1. 概述

NY5B 系列產品為多功能單晶片CMOS語音合成 4 位元微控制器，提供 4 通道的語音/Midi合成功能，語音合成方式採用先進的高音質ADPCM演算法，最高採樣率可達CD音質 44.1kHz，且硬體有 16 階的音量控制。提供兩種聲音輸出方式可供選擇，一種PWM輸出和一種DAC輸出。使用RISC精簡指令集架構，共有 48 條指令，除了少數指令需要 2 個時序，大多數指令都是 1 個時序即可完成，可以很方便的以程式控制來完成不同的應用。利用精準的 $\pm 1\%$ 內阻震盪，客戶可以不需外加震盪電阻，但是彈性的預留一個OSC腳位可以外接震盪電阻，當只使用內阻震盪時，此腳可以當作一般I/O腳使用。提供待機模式(Halt mode)，可大幅度的節省功耗；另外還提供慢速模式(Slow mode)，可以降低功耗。

2. 功能

- 寬廣的工作電壓：2.0V ~ 5.5V。
- 4-bit RISC 精簡指令集架構的微控制器，共有 48 條指令。
- 共有 15 個母體，，最大母體的ROM容量為 160Kx10-bit，程式和資料共用同一塊ROM。

| 產品編號 | 語音長度 (秒) @6kHz | ROM 容量 (10-bit) |
|-----------------|-------------------|-----------------|
| NY5B005C | 5.0 | 16k x 10 |
| NY5B008C | 8.3 | 24k x 10 |
| NY5B011C | 11.7 | 32k x 10 |
| NY5B018C | 18.3 | 48k x 10 |
| NY5B025C | 25.0 | 64k x 10 |
| NY5B035C | 35.0 | 88k x 10 |
| NY5B046C | 45.0 | 112k x 10 |
| NY5B055C | 55.0 | 136k x 10 |
| NY5B065C | 65.0 | 160k x 10 |
| NY5B075C | 75.0 | 184k x 10 |
| NY5B085C | 85.0 | 208k x 10 |
| NY5B112C | 111.7 | 272k x 10 |
| NY5B132C | 131.7 | 320k x 10 |
| NY5B158C | 158.3 | 384k x 10 |
| NY5B185C | 185.0 | 448k x 10 |

- 224x4-bit RAM，分成 4 頁，每頁 56x4-bit。
- 1MHz 或 **2MHz** 指令頻率。
- 提供慢速模式(Slow mode)，可降低功耗。*(注意: 由於慢速模式的時間誤差較大，不建議使用在計時的應用)*
- 提供待機模式(Halt mode)，可節省功耗，靜態電流(Isb)小於 1uA。
- 精準的 $\pm 1\%$ 內阻震盪；另外還提供外阻震盪選擇，以便調整速度。
- 提供低壓復位(LVR=1.8V)，看門狗計時(WDT)，I/O復位功能(External Reset)。

- 一個中斷輸入可連結到一組獨立的堆棧(Stack)，並有多種中斷來源可以使用。
- 15 根彈性的I/O腳，可設定為input, output, large current output, IO, floating-type reset, pull-high reset, IR carrier output 和 large current IR carrier output 等輸入輸出功能。當做為輸出時，可以選擇為一般輸出電流 (Normal Drive Current, Normal Sink Current) 或是大電流輸出(Large Sink Current)，可直推高亮度LED，不需外加三級管。
- 支援Open-Drain (OD) 的雙向I/O。
- IR紅外線輸出: 提供 31kHz~58kHz可選擇的紅外線頻率輸出，並可選擇高電平/低電平編碼。(光罩選擇)
(5B112C、5B132C、5B158C、5B185C：無IR紅外線輸出功能)。
- OSC/PD2 可以當做OSC腳來連接外部震盪電阻，或是正常的I/O腳PD2。(光罩選擇)
- 提供 4 通道的語音/Midi合成功能，可以單獨設定每個通道為語音或Midi輸出。
- 更先進的高音質ADPCM語音合成演算法，可以經由簡單的調整採樣位數來提升音質。
- 提供 256 點, ADSR 和 Full-Wave 3 種音色合成方法，用於進行不同Midi音色的編輯。
- 內建 256 階Midi包絡線控制(Envelope Control)，用於進行Midi音量的控制。
- 一組 9-bit PWM純硬體輸出，可以直接驅動喇叭或蜂鳴片；一組 10-bit DAC純硬體輸出，可以外加放大線路來放大音量 (通常用於多通道輸出)。
- 提供大音量PWM輸出，可以直接輸出更大音量，輸出語音不需外加三級管放大。
- 內建 16 階硬體音量控制(Volume Control)，用於進行整體音量的控制。
- 支援 Quick-IO 訊號控制。

1. GENERAL DESCRIPTION

The NY5B series IC is a powerful 4-bit micro-controller based sound processor. There are 4 channels that are configured as speech or Midi, and all of them can be auto-played back simultaneously. By using the high fidelity ADPCM speech synthesis algorithm, it can produce outstanding quality voices. Wide range sampling rate up to 44.1kHz of CD quality and 16 different volume levels are supported. It is also equipped two kinds of audio outputs with fine resolution, including a current D/A converter and a PWM direct-drive. The RISC MCU architecture is very easy to program and control, various applications can be easily implemented. There are 48 instructions, and most of them are executed in single cycle. Through +/-1% accurate internal oscillation, external Rosc is mostly unnecessary. Also an OSC pad is reserved for external oscillation, and this pad can be optioned as normal I/O when setting internal oscillation only. Furthermore, in addition to the HALT mode (sleep mode), it also offers the SLOW mode to minimize power dissipation.

2. FEATURES

- Wide operating voltage range: 2.0V to 5.5V.
- 4-bit RISC type micro-controller with 48 instructions.
- There are 15 bodies. 208Kx10-bit ROM is the maximum. Program and voice data share the same ROM space.

| Product | Voice Duration (sec) @6kHz | ROM Size (10-bit) |
|-----------------|-------------------------------|-------------------|
| NY5B005C | 5.0 | 16k x 10 |
| NY5B008C | 8.3 | 24k x 10 |
| NY5B011C | 11.7 | 32k x 10 |
| NY5B018C | 18.3 | 48k x 10 |
| NY5B025C | 25.0 | 64k x 10 |
| NY5B035C | 35.0 | 88k x 10 |
| NY5B046C | 45.0 | 112k x 10 |
| NY5B055C | 55.0 | 136k x 10 |
| NY5B065C | 65.0 | 160k x 10 |
| NY5B075C | 75.0 | 184k x 10 |
| NY5B085C | 85.0 | 208k x 10 |
| NY5B112C | 111.7 | 272k x 10 |
| NY5B132C | 131.7 | 320k x 10 |
| NY5B158C | 158.3 | 384k x 10 |
| NY5B185C | 185.0 | 448k x 10 |

- 224x4-bit RAM, divided into 4 pages.
- 1MHz or **2MHz** instruction frequency.

- SLOW mode to operate at low power consumption. *(Not suggest using in Timer/Clock application.)*
- HALT mode to save power, less than 1uA@3V standby current.
- Precisely embedded oscillator with build-in resistor (+/- 1%). External resistor to adjust system frequency is optional.
- Low voltage reset (LVR=1.8V), watch-dog reset and I/O port reset are all supported to protect the system.
- One interrupt entrance with an independent stack, multiple interrupt sources.
- 15 flexible I/Os with optional function: input, output, large current output, IO, floating-type reset, pull-high reset, IR carrier output and large current IR carrier output. For the output port, users can select the normal Drive current output or large Sink current output to directly drive high brightness LED.
- Support Open-Drain (OD) bi-direction IO.
- Infrared output: optional IR carrier frequency and optional data high/low IR output supported. *(Mask Option) (5B112C, 5B132C, 5B158C and 5B185C: No Infrared output function).*
- Shared OSC/PD2 pad, it can be used as external OSC pad to apply external resistor or PD2 function by mask option. *(Mask Option)* .
- Maximum of 4 channels can play simultaneously, each channel can be arbitrarily assigned as speech or Midi channel.
- New high fidelity ADPCM speech synthesis algorithm.
- 3 kinds of 256 points, ADSR and Full-Wave instrument waveform provide outstanding midi quality for MIDI.
- 256 steps envelope control for MIDI.
- High quality 9-bit PWM to directly drive speaker, or 10-bit D/A converter audio output to amplify the volume by external audio amplifier for multi-channel MIDI especially.
- Support large PWM current output.
- 16 steps volume control for audio output.
- Quick-IO control supported.

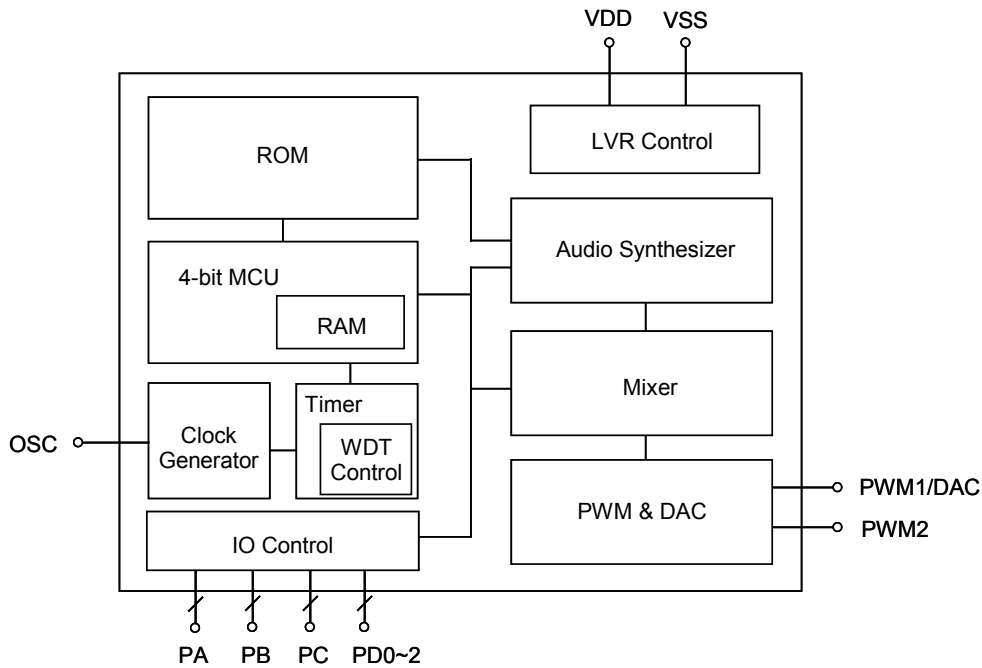
3. BLOCK DIAGRAM

4. PAD DESCRIPTION

| Pad Name | ATTR. | Description |
|----------|--------|---|
| VDD1~2 | Power | Positive power. |
| GND1~2 | Power | Negative power. |
| PA0~3 | I/O | Bit 0~3 for Port A |
| PB0~3 | I/O | Bit 0~3 for Port B |
| PC0~3 | I/O | Bit 0~3 for Port C |
| PD0~1 | I/O | Bit 0~1 for Port D |
| OSC/PD2 | I, I/O | External resistor for oscillator input, or PD2. |
| PWM1/DAC | O | PWM1 output or DAC output. |
| PWM2 | O | PWM2 output. |

5. MEMORY ORGANIZATION

There are maximum 208K words ROM, 224 nibbles of RAM and 17 nibbles of dedicated system control register. The registers are divided into 9 nibbles of system registers and 8 nibbles of memory registers. Besides, there are several registers without address allocation, and they can only be accessed by the special instructions. One of the registers is RAM page register (PG), and the others are audio control registers.

5.1 ROM

A large program/data/voice single ROM is provided, and its structure is shown below. The reserved region contains system information and can't be utilized by users. The program page is limited by the unconditional branch instruction: JMP and CALL. Because it can only handle 14-bit length address of ROM, the program page size is 16K words.

| Address | ROM |
|----------------------|--|
| 0x000000 | Reset Vector |
| 0x00000F 0x000010 | Interrupt Vector |
| 0x00001E 0x00001F | Reserved |
| 0x000BFF 0x000C00 | Program & Data Space Program Page 0 |
| 0x003FFF 0x004000 | Program & Data Space |

5.2 RAM

Each page of RAM contains 56 nibbles, and there are totally 4 pages. The page number (PG) register of RAM is defined by the MPG instruction, and its initial value is 0. Because the memory space is shared with the memory registers (address=0x00~0x07), the address for RAM is 0x08~0x3F.

In addition to the immediate addressing mode, the indexed addressing mode is also supported. The page and address of the indexed RAM should be stored into RPT1 and RPT0 first, and users can read from or write in the XMD memory register to realize the indexed ROM access.

6. CLOCK GENERATOR

The clock generator is a Ring oscillator, and users can select the internal resistor (INT-R) or the external resistor (EXT-R). A precise INT-R oscillator is provided, and its accuracy is up to $\pm 1\%$.

If OSC/PD2 pad is optioned as PD2 I/O function, there is only INT-R, and EXT-R is disabled. When this pad is optioned as OSC function oppositely, INT-R or EXT-R can be determined by the configurations below.

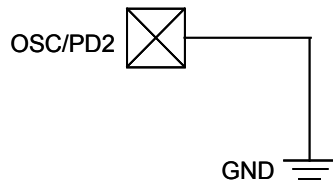

INT-R Oscillator Connection

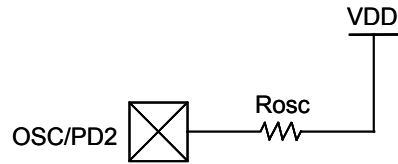

EXT-R Oscillator Connection

7. IO PORTS

There are most 15 I/O ports, designated as PAx through PCx with x=0~3 and PDx with x=0~2. All the I/O ports can be configured as input, output, or IO port (bi-direction). For the input port, we provide an internal pull-high register option for convenience. For the output port, users can also option its initial value as low or high according to your application circuit. Besides, users can also enable the large current option for each output port to get a larger sink current. The bi-direction IO port can be an input or output by its register value, and users can option the bi-direction IO with a pull-high resistor or without a pull-high resistor (Open-Drain). When the register equals 0, it is an output and can only output zero. When the register equals 1, it is a weak pull-high or floating (Open-Drain) so that it also can be considered as an input port with/without a pull-high resistor. Users also can enable the large sink current option of an IO port.

The PX0 port means the PA0, PB0, PC0 or PD0 port can also be optioned as an external reset pin or an infrared (IR) output pin. A reset port can possess a pull-high resistor or not, and an IR port can be initial low or high and also large sink current or not.

The pull-high resistor of all the I/O ports has two kinds of option: weak and strong. The weak one is about 850K Ω @3V for normal application and the strong one is about 480K Ω @3V usually for key matrix function. When users configure the weak or strong pull-high resistor, the pull-high resistors of all I/O ports are set as the option value.

Please note that PD2 pad is shared with external OSC pad. When users enable external OSC function, PD2 function will be disabled.

8. AUDIO SYNTHESIZER

There are 4-ch speech or Midi, and all modes are auto-played back by hardware. Different channel mode possesses different hardware structure. It provides a hardware mixer to mix the channel data. The mixer contains a mixer control register MIX. Mixed 1-ch ~ 4-ch voice and/or Midi are all configurable by programming the MIX. Two audio output stages: DAC and PWM are supported.

8.1 Voice

A voice channel includes a PFLG, a VPR, a voice decoder, a QIO control code generator and an 8-bit sample rate timer (TM) whose timer clock source (TCS) is fixed to 1MHz. It supports PCM and encoded ADPCM speech data.

8.2 Midi

A Midi channel includes a PFLG, a VPR, a TM, an ENV, a timbre skipper and a multiplier, which multiplies the Midi data and the envelope value held by the ENV. The timbre skipper is used to fulfill the higher octave pitch playing. The hardware multiplier is dedicated to the Midi channel, and users can't operate it by any instruction.

8.3 Audio Output

By set the AUD register, PWM or DAC can be easily chosen as the audio output stage. Besides, it provides a pad detecting mechanism. The pad detecting mechanism detects the PWM2 pad during the reset initialization period, and sets the initial value of the audio output register as PWM if the PWM2 connection is floating, or sets the initial value of the audio output register as DAC if the PWM2 connection is high. In conclusion, connect the speaker to PWM1 and PWM2 only if using PWM, otherwise connect PWM2 to VDD if using DAC. Since the mechanism sets only the initial value of AUD, don't change the value of the AUD register if the pad detecting mechanism is adopted.

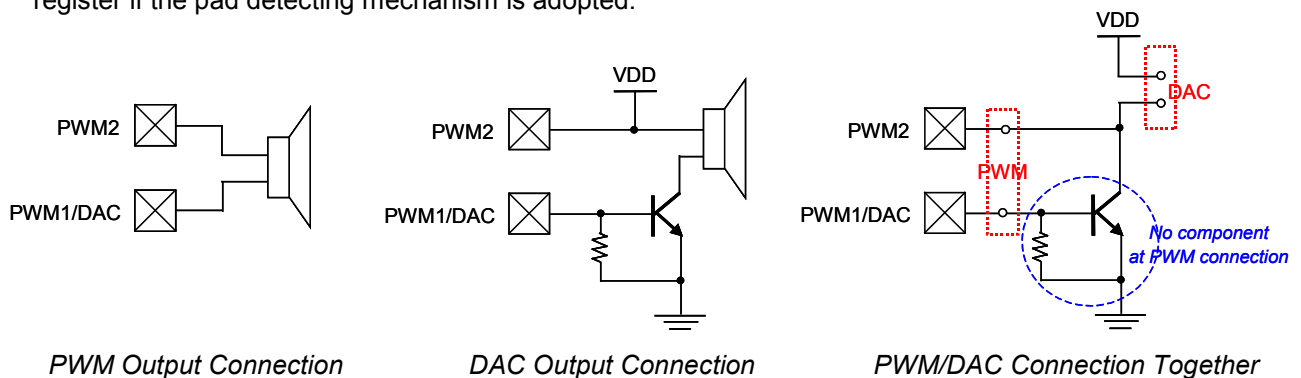

When using the PWM output, we provide an option of normal PWM current or large PWM current for different customer demand. The large PWM consumes more current and makes sound louder.

8.4 Volume Control

Both PWM and DAC supports 16 steps hardware volume control by the VOL register.

9. ELECTRICAL CHARACTERISTICS
9.1 Absolute Maximum Rating

| Symbol | Parameter | Rated Value | Unit |
|-----------|-----------------------|--------------------|------|
| Vdd - Vss | Supply voltage | -0.5 ~ +6.0 | V |
| Vin | Input voltage | Vss-0.3V ~ Vdd+0.3 | V |
| Top | Operating Temperature | 0 ~ +70 | °C |
| Tst | Storage Temperature | -25 ~ +85 | °C |

9.2 DC Characteristics

| Symbol | Parameter | | VDD | Min. | Typ. | Max. | Unit | Condition | |
|--------|-------------------------------------|--------------------|-----|------|---------------|------|------|---|------------------|
| VDD | Operating voltage | | | 2.0 | 3 | 5.5 | V | 1MHz & 2MHz | |
| Isb | Supply current | Halt mode | 3 | | | 1 | uA | Sleep, no loading | |
| | | | 4.5 | | | 1 | | | |
| Isl | | Slow mode | 3 | | 150 | | uA | 1ms interrupt, no load | |
| | | | 4.5 | | 350 | | | | |
| Iop | | Operating mode | | 3 | | 1.2 | | mA | 1MHz, no loading |
| | | | | 4.5 | | 3 | | | |
| | 3 | | | | 1.5 | | mA | | |
| 4.5 | | 3.5 | | | | | | | |
| Iil | Input current (Internal pull-high) | Weak (850k ohms) | 3 | | -3.5 | | uA | Vii=0v | |
| | | | 4.5 | | -10 | | | | |
| | | Strong (480k ohms) | 3 | | -7 | | uA | | |
| | | | 4.5 | | -20 | | | | |
| Ioh | Output high current | | 3 | | -10 | | mA | Voh=1.0V | |
| | | | 4.5 | | -22 | | | Voh=2.2V | |
| Iol | Output low current (Normal current) | | 3 | | 10 | | mA | Voi=2.0V | |
| | | | 4.5 | | 20 | | | Voi=2.5V | |
| | Output low current (Large current) | | 3 | | 20 | | mA | Voi=2.0V | |
| | | | 4.5 | | 40 | | | Voi=2.5V | |
| IPWM | PWM output current (Normal) | | 3 | | 60 | | mA | Load=8 ohms | |
| | | | 4.5 | | 100 | | | | |
| | PWM output current (Large) | | 3 | | 70 | | mA | Load=8 ohms | |
| | | | 4.5 | | 117 | | | | |
| IDAC | DAC output current | | 3 | | -0.36 ~ -4.20 | | mA | Half scale | |
| | | | 4.5 | | -0.47 ~ -4.85 | | | | |
| ΔF/F | Frequency deviation by voltage drop | | 3 | | 1.0 | | % | $\frac{F_{osc}(3.0v)-F_{osc}(2.4v)}{F_{osc}(3v)}$ | |
| | | | 4.5 | | -0.5 | | | $\frac{F_{osc}(4.5v)-F_{osc}(3.0v)}{F_{osc}(4.5v)}$ | |
| ΔF/F | Frequency lot deviation | | 3 | -1 | | 1 | % | $\frac{F_{max}(3.0v)-F_{min}(3.0v)}{F_{max}(3.0v)}$ | |
| Fosc | Oscillation Frequency | | - | 0.90 | 1 | 1.05 | MHz | VDD=2.0~5.5V | |
| | | | | 1.80 | 2 | 2.10 | | | |

9.3 Voltage vs. Frequency

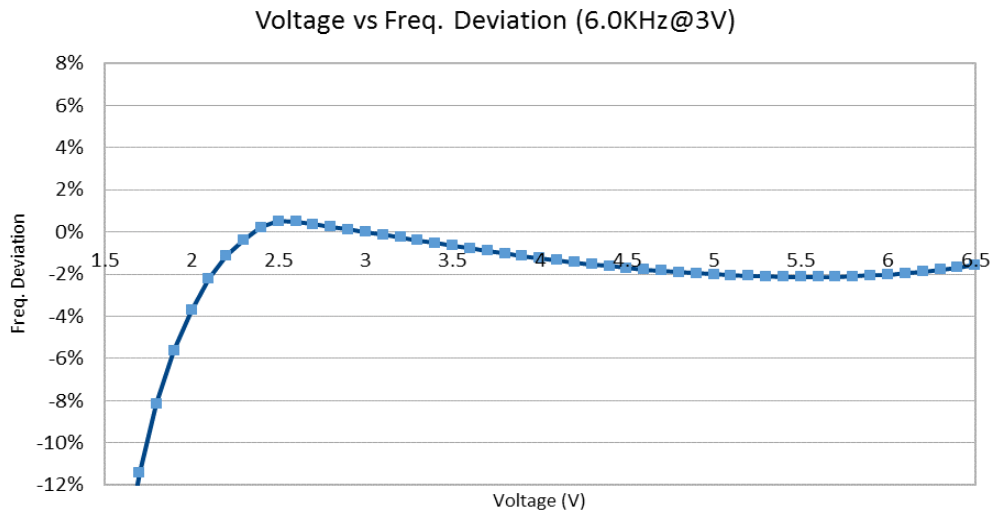
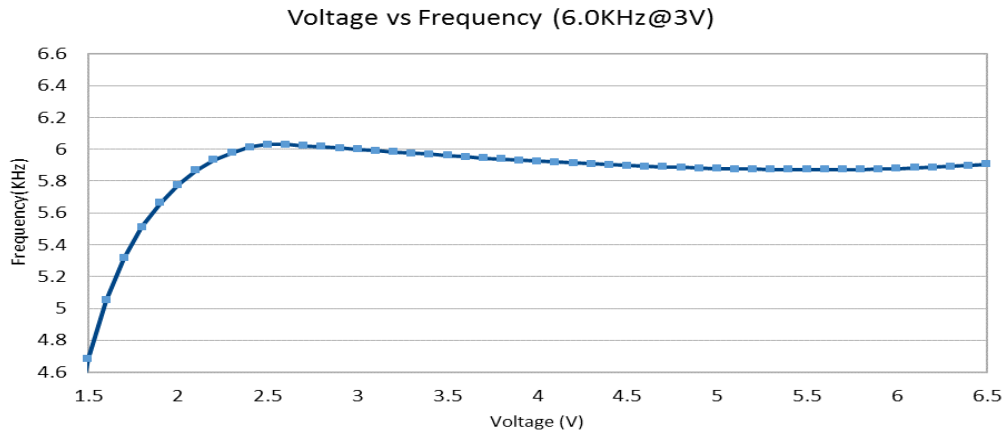

9.4 System Frequency v.s. External Rosc

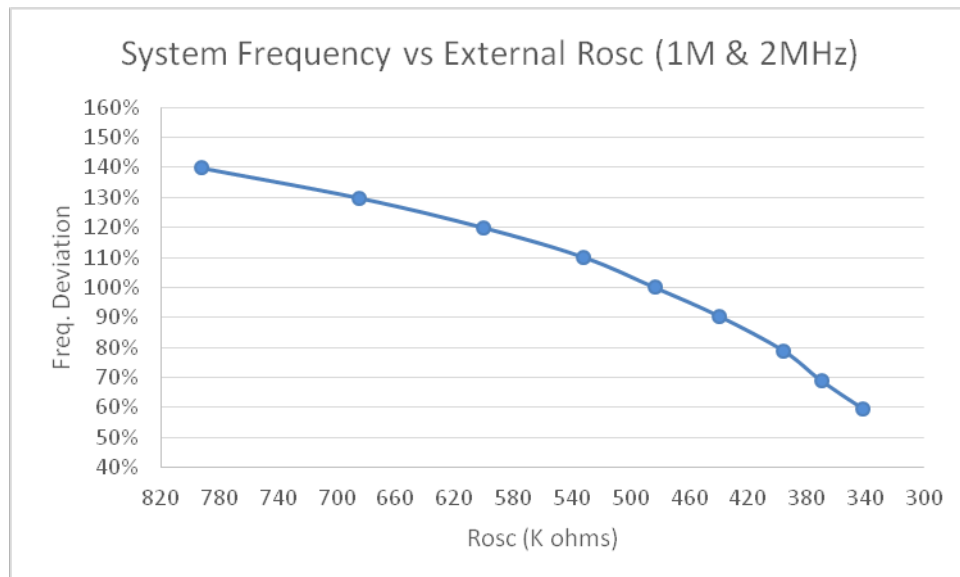

10. APPLICATION

(1) INT-R, PWM (OSC/PD2 is optioned as PD2 pad)

(2) EXT-R, DAC (OSC/PD2 is optioned as OSC pad)

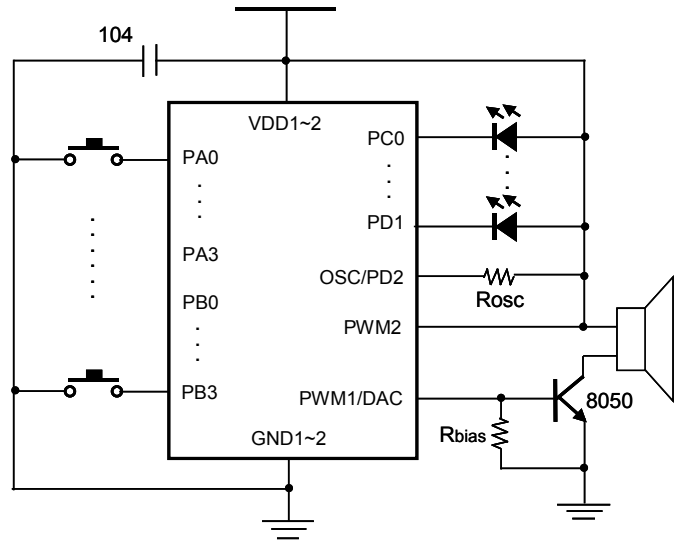
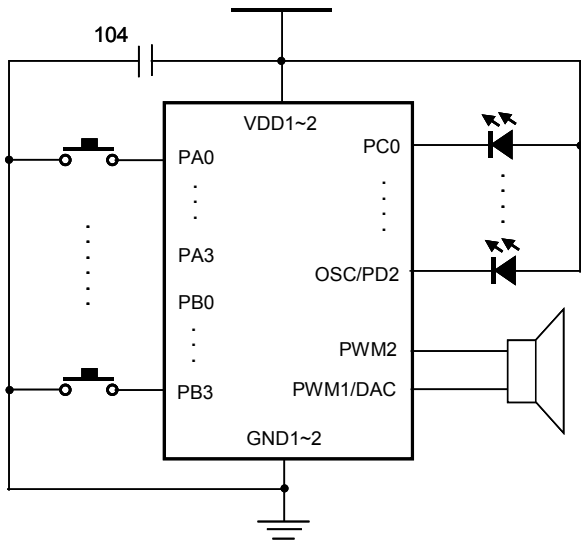

(3) INT-R, PWM (OSC/PD2 is optioned as OSC pad)

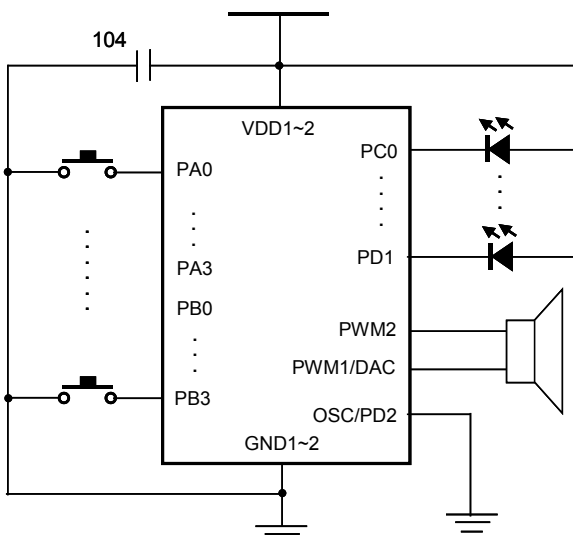

11. DIE PAD DIAGRAM

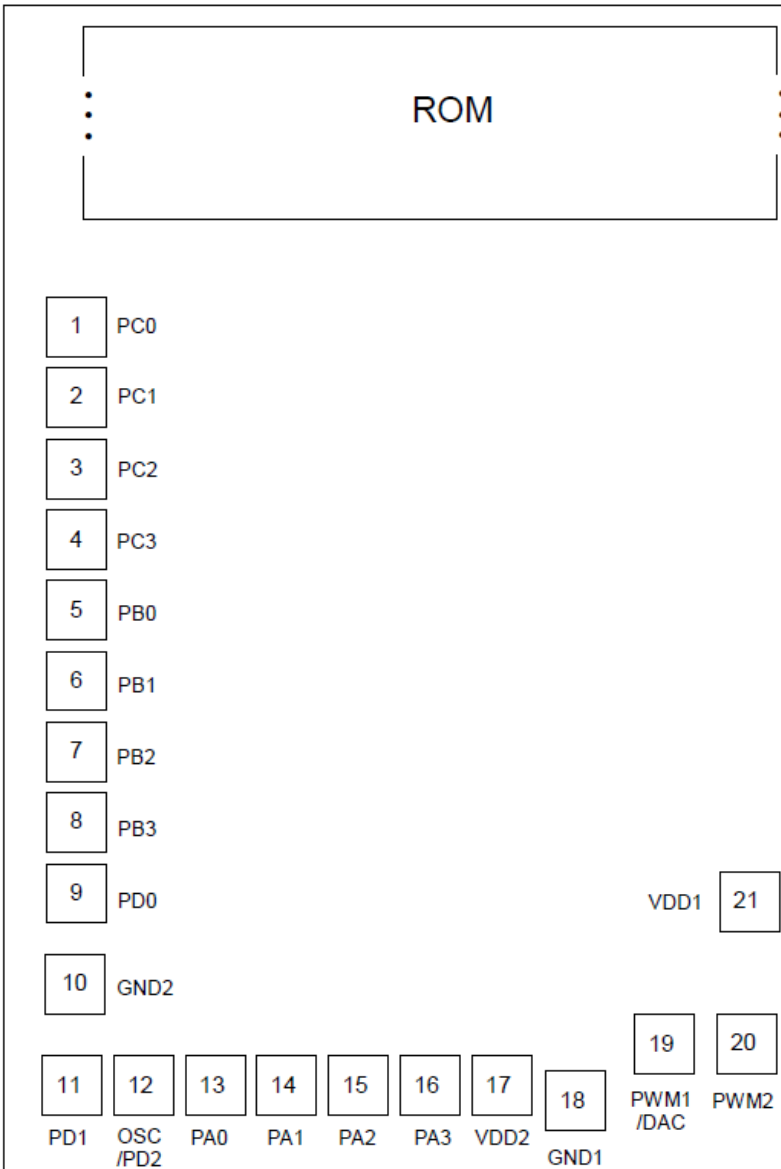

* The IC substrate must be connected to GND or Floating.