



九齊科技股份有限公司
Nyquest Technology Co., Ltd.

DATA SHEET

NY4B Series

**Single-Chip 4-bit MCU with 1-Ch Speech
& 8 I/O**

Version 2.0

Jan. 27, 2021

NYQUEST TECHNOLOGY CO. reserves the right to change this document without prior notice. Information provided by NYQUEST is believed to be accurate and reliable. However, NYQUEST makes no warranty for any errors which may appear in this document. Contact NYQUEST to obtain the latest version of device specifications before placing your orders. No responsibility is assumed by NYQUEST for any infringement of patent or other rights of third parties which may result from its use. In addition, NYQUEST products are not authorized for use as critical components in life support devices/systems or aviation devices/systems, where a malfunction or failure of the product may reasonably be expected to result in significant injury to the user, without the express written approval of NYQUEST.

Revision History

Version	Date	Description	Modified Page
1.0	2009/12/21	Formally release.	-
1.1	2010/2/12	NY4B provides large PWM current output. Add Noise-Filter description.	4, 6, 7 6
1.2	2010/3/18	Modify "Bonding Diagram" pad no.4 to PB0 from PB2.	10
1.3	2010/6/21	Add new bodies of NY4B003A ~ NY4B011A. Modify "Voltage vs. Frequency" curve.	3 8
1.4	2010/9/08	1. Modify SRAM description. 2. Modify I/O port description for IR and reset options.	3 6
1.5	2011/1/05	Add Chinese description for Chapter 1 & 2.	3, 4
1.6	2013/5/23	1. Change NY4BxxxA to NY4Bxxx B . 2. Add new bodies of NY4B115B ~ NY4B165B. 3. Modify "Voltage vs. Frequency" curve.	3, 5 3, 5 11
1.7	2013/8/26	Revise the I _{ol} value at VDD=4.5V.	10
1.8	2014/11/21	Change IC body: NY4B018C, NY4B038C and NY4B058C.	3, 5
1.9	2018/02/09	Update the DC Characteristics table.	10
2.0	2021/01/27	Remove NY4B075B / 85B / 95B / 105B/ 115B / 125B / 145B / 165B.	-

1. 概述

NY4B系列產品為單晶片CMOS語音合成4位元微控制器，提供一通道的語音輸出，有一組高音質的PWM來直推喇叭。語音合成方式採用高音質ADPCM演算法，最高採樣率可達CD音質44.1kHz，且內建一個雜訊濾波線路可降低背景噪音。使用RISC精簡指令集架構，共有44條指令，除了少數指令需要2個時序，大多數指令都是1個時序即可完成，可以很方便的以程式控制來完成不同的應用。利用精準的+/-1%內阻震盪，可以不需外加震盪電阻。提供待機模式(Halt mode)，可大幅度的節省功耗。

2. 功能

- 寬廣的工作電壓：2.0V ~ 5.5V。
- 4-bit RISC 精簡指令集架構的微控制器，共有44條指令。
- 共有14個母體，最大母體的ROM容量為400Kx10-bit，程式和資料共用同一塊ROM。

產品編號	語音長度 (秒) @6kHz	ROM 容量 (10-bit)
NY4B003B	3.3	12k x 10
NY4B005B	5.0	16k x 10
NY4B008B	8.3	24k x 10
NY4B011B	11.7	32k x 10
NY4B018C	18.3	48k x 10
NY4B025B	25.0	64k x 10
NY4B038C	38.3	96k x 10
NY4B045B	45.0	112k x 10
NY4B058C	58.3	144k x 10
NY4B065B	65.0	160k x 10

- 96x4-bit RAM，分成2頁，每頁48x4-bit。
- 1MHz 指令頻率。
- 提供待機模式(Halt mode)，可節省功耗，靜態電流(Isb)小於1uA。
- 精準的+/-1%內阻震盪。
- 提供低壓復位(LVR=1.8V)，看門狗計時(WDT)，I/O復位功能(External Reset)。
- 有8根彈性的I/O腳，可設定為floating, pull-high, strong / weak pull-high, Reset input, IR carrier output 等輸入輸出功能。I/O可以用寄存器來作軟體控制選擇為輸入或輸出，當做為輸出時，可以選擇為一般輸出電流(Normal Drive Current)或是大電流輸出(Large Sink Current)，可直推高亮度LED，不需外加三級管。
- IR紅外線輸出：提供31kHz~58kHz可選擇的紅外線頻率輸出，並可選擇高電平/低電平編碼。
- 高音質ADPCM語音合成演算法，可以經由簡單的調整採樣位數來提升音質。

- 內建雜訊濾波線路(Noise-Filter)，可以適當的降低背景噪音。
- 一組9-bit PWM純硬體輸出，可以直接驅動喇叭或蜂鳴片。
- 提供大音量PWM輸出，可以直接輸出更大音量，不需外加三級管放大。*(NY4A不支援此功能)*
- 內建硬體的靜音壓縮演算法(Mute mode speech algorithm)，可以節省語音容量。
- 支援 Quick-IO 訊號控制。

1. GENERAL DESCRIPTION

The NY4B series IC is a powerful 4-bit micro-controller based sound processor. There is only 1-channel speech with high quality direct-drive PWM output. By using the high fidelity ADPCM speech synthesis algorithm and a built-in noise filter, it can produce outstanding quality voices. Wide range sampling rate up to 44.1kHz is supported. The RISC MCU architecture is very easy to program and control, various applications can be easily implemented. There are 44 instructions, and most of them are executed in single cycle. Through +/-1% accurate internal oscillation, external R_{osc} is unnecessary. Furthermore, a HALT mode (sleep mode) is designed to minimize power dissipation.

2. FEATURES

- Wide operating voltage range: 2.0V to 5.5V.
- 4-bit RISC type micro-controller with 44 instructions.
- There are 14 bodies. 400Kx10-bit ROM is the maximum. Program and voice data share the same ROM space.

Product	Voice Duration (sec) @6kHz	ROM Size (10-bit)
NY4B003B	3.3	12k x 10
NY4B005B	5.0	16k x 10
NY4B008B	8.3	24k x 10
NY4B011B	11.7	32k x 10
NY4B018C	18.3	48k x 10
NY4B025B	25.0	64k x 10
NY4B038C	38.3	96k x 10
NY4B045B	45.0	112k x 10
NY4B058C	58.3	144k x 10
NY4B065B	65.0	160k x 10

- 96x4-bit RAM, divided into 2 pages.
- 1MHz instruction frequency.
- HALT mode to save power, less than 1uA standby current.
- Precisely embedded oscillator with build-in resistor R_{osc} (+/- 1%).
- Low voltage reset (*LVR=1.8V*), watch-dog reset and I/O port reset are all supported to protect the system.
- Maximum 8 flexible I/Os with optional function: floating, pull-high, strong / weak pull-high, Reset input, IR carrier output. I/O's direction is controlled by registers. For the output port, users can select the large sink current output or normal drive current output.
- Infrared output: optional IR carrier frequency and optional data high/low IR output supported.
- New high fidelity ADPCM speech synthesis algorithm.

- Built-in noise filter for less background noise at lower volume especially.
- One 9-bit hardware PWM output.
- Support large PWM current output. *(Only for NY4B series. NY4A don't provide this function.)*
- Mute mode speech algorithm to save ROM size.
- Quick-IO control supported.

3. BLOCK DIAGRAM

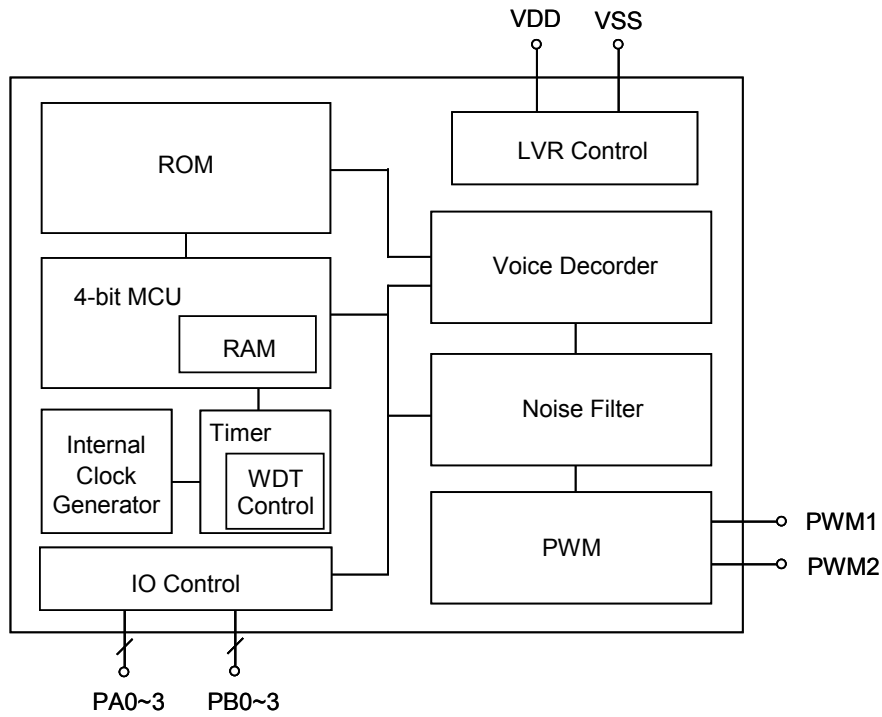

4. PAD DESCRIPTION

Pad Name	ATTR.	Description
VDD1~2	Power	Positive power.
GND1~2	Power	Negative power.
PA0~3	I/O	Bit 0~3 for Port A.
PB0~1	I/O	Bit 0~1 for Port B.
PB2/IR	I/O	Bit 2 for Port B, or IR transmitter pin.
PB3/Reset	I/O	Bit 3 for Port B, or external reset pin.
PWM1	O	PWM1 output.
PWM2	O	PWM2 output.

5. MEMORY ORGANIZATION

There are maximum 400K words ROM, 96 nibbles of RAM and 14 nibbles of dedicated system control register. Besides, there are several registers without address allocation, and they can only be accessed by the special instructions. One of the registers is RAM page register (PG), and the other one is 8 bit sample rate timer (TM).

5.1 ROM

A large program/data/voice single ROM is provided, and its structure is shown below. The reserved region contains system information and can't be utilized by users. The program page is limited by the unconditional branch instruction: JMP and CALL. Because it can only handle 14-bit length address of ROM, the program page size is 16K words.

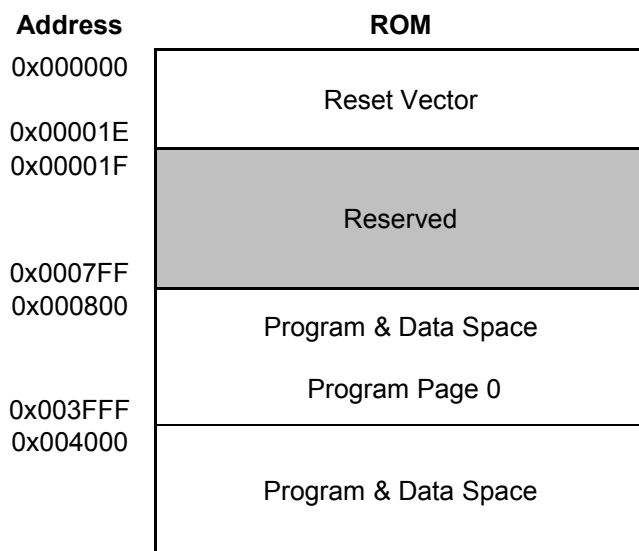

5.2 RAM

Each page of RAM contains 48 nibbles, and NY4B serial provides 96 nibbles of 2 pages. The page number (PG) register of RAM defined by the MPG instruction, and its initial value is 0. The address for RAM is 0x10~0x3F.

6. CLOCK GENERATOR

The clock generator is a Ring oscillator, and users can only select the internal resistor (INT-R). The INT-R oscillator accuracy is up to $\pm 1\%$.

7. IO PORTS

There are 8 I/O pins at most, designated as PAX through PBx, and x=0~3. All the I/O ports can be configured as input or output by registers. For the input port, we provide an internal pull-high register option for convenience. For the output port, users can select the large sink current output or normal drive current output.

The PB2 pin can be optioned as an infrared (IR) output pin. The PB3 pin can be optioned as an external reset pin. A reset port can possess a pull-high resistor or not, and an IR port can be large sink current or normal drive current output.

The pull-high resistor of all the I/O ports has two kinds of option: weak and strong. The weak one is about 750kΩ @3V for normal application and the strong one is about 33kΩ @3V usually for key matrix function. When users configure the weak or strong pull-high resistor, the pull-high resistors of all I/O ports are set as the option value.

8. AUDIO SYNTHESIZER

There is 1-ch voice, and all modes are auto-played back by hardware. One audio output stages: 9-bit PWM is supported. The NY4 series supports 9-bit PCM and encoded ADPCM speech data. Of course, the PCM speech has higher quality and occupies more ROM space than the ADPCM one. Use the encode software provided by the Nyquest to generate the PCM or ADPCM speech data. The voice start address is loading to VPR when executing the PLAY command.

There is an option of normal PWM current or large PWM current for different customer demand. The large PWM current consumes more current and makes sound louder. *(NY4A don't support the large PWM output.)*

A Noise-Filter is built-in. When users enable this option, hardware will suppress the noise to reduce the background noise automatically. Users can also disable this option up to the sound source.

A voice channel includes a PFLG, a VPR, a voice decoder, a QIO control code generator and an 8-bit sample rate timer (TM) whose timer clock source (TCS) is fixed to 1MHz. It supports PCM and encoded ADPCM speech data.

The NY4 series supports another special mute mode for speech. When a speech like the vocal or talk has a lot of suspension or silence, using the mute mode saves much ROM space. Turn on the mute mode option of the encode software to save your cost.

9. ELECTRICAL CHARACTERISTICS
9.1 Absolute Maximum Rating

Symbol	Parameter	Rated Value	Unit
V _{DD} - V _{SS}	Supply voltage	-0.5 ~ +6.0	V
V _{in}	Input voltage	V _{SS} -0.3V ~ V _{DD} +0.3	V
T _{op}	Operating Temperature	0 ~ +70	°C
T _{st}	Storage Temperature	-25 ~ +85	°C

9.2 DC Characteristics

Symbol	Parameter		V _{DD}	Min.	Typ.	Max.	Unit	Condition
V _{DD}	Operating voltage			2.0	3	5.5	V	1 MHz
I _{sb}	Supply current	Halt mode	3			1	uA	Sleep, no load
			4.5			1		
I _{op}	Operating mode		3		0.5		mA	1MHz, no loading
			4.5		1.5			
I _{il}	Input current (Internal pull-high)	Weak (750k ohms)	3		-4		uA	V _{il} =0v
			4.5		-11			
		Strong (33k ohms)	3		-90			
			4.5		-225			
I _{oh}	Output high current		3		-8		mA	V _{oh} =2.0V
			4.5		-12			V _{oh} =3.5V
I _{ol}	Output low current (Large current)		3		18		mA	V _{ol} =1.0V
			4.5		25			V _{ol} =1.0V
I _{PWM}	PWM output current (Normal)		3		60		mA	Load=8 ohms
			4.5		100			
I _{PWM}	PWM output current (Large)		3		70		mA	Load=8 ohms
			4.5		117			
ΔF/F	Frequency deviation by voltage drop (1MHz)		3		1.5		%	$\frac{F_{osc}(3.0v)-F_{osc}(2.4v)}{F_{osc}(3v)}$
			4.5		-0.5			$\frac{F_{osc}(4.5v)-F_{osc}(3.0v)}{F_{osc}(4.5v)}$
ΔF/F	Frequency lot deviation (1MHz)		3	-1		1	%	$\frac{F_{osc}(3.0v)-1MHz}{1MHz}$
F _{osc}	Oscillation Frequency		-	0.90	1	1.05	MHz	V _{DD} =2.0~5.5V

9.3 Voltage vs. Frequency

Voltage vs Frequency (6.0KHz@3V)

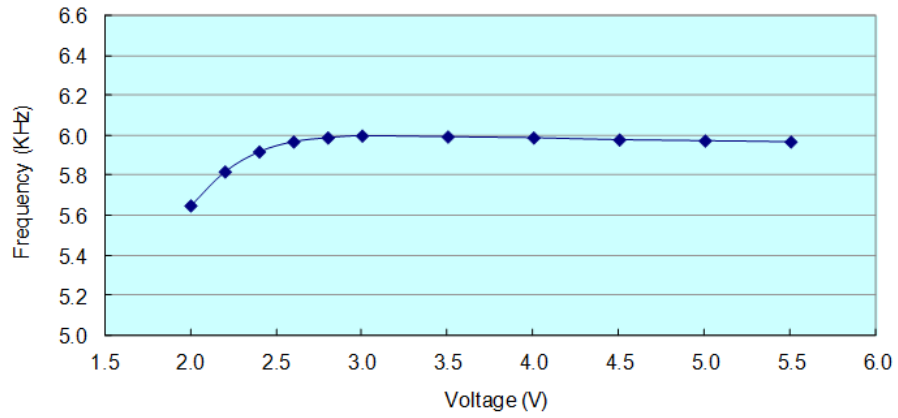

Voltage vs Freq. Deviation (6.0KHz@3V)

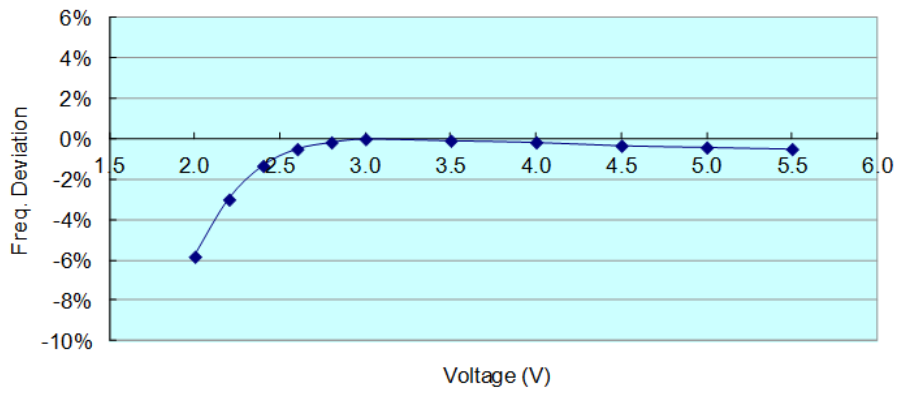

10. APPLICATION

(1) INT-R, PWM, Sink output with 4 LEDs

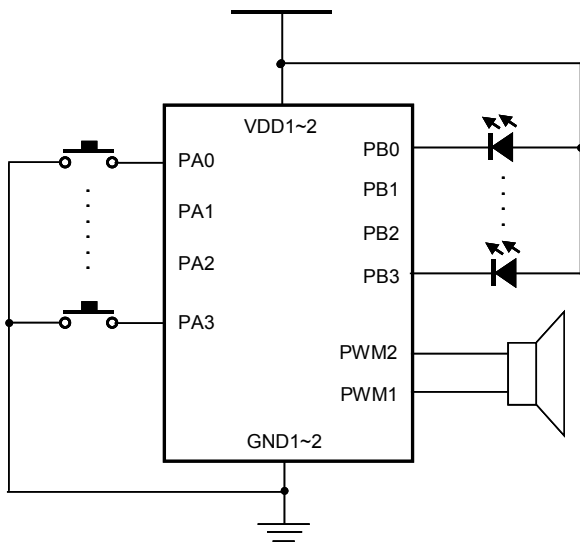

(2) INT-R, PWM, Drive output with 4 LEDs

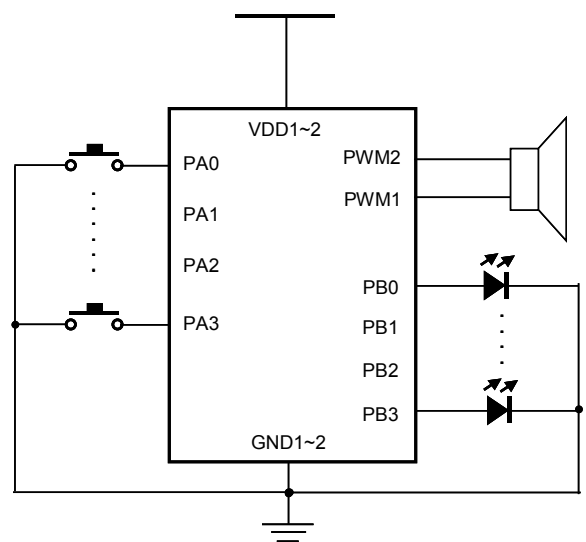

(3) INT-R, PWM, Sink output with 3 LEDs and 1 Motor

