



九齊科技股份有限公司
Nyquest Technology Co., Ltd.

DATA SHEET

NY4PxxxJ Series (OTP for NY4)

**Single-Chip 4-bit MCU with 1-Ch Speech
& 8 I/O**

Version 1.3

Jan. 27, 2021

NYQUEST TECHNOLOGY CO. reserves the right to change this document without prior notice. Information provided by NYQUEST is believed to be accurate and reliable. However, NYQUEST makes no warranty for any errors which may appear in this document. Contact NYQUEST to obtain the latest version of device specifications before placing your orders. No responsibility is assumed by NYQUEST for any infringement of patent or other rights of third parties which may result from its use. In addition, NYQUEST products are not authorized for use as critical components in life support devices/systems or aviation devices/systems, where a malfunction or failure of the product may reasonably be expected to result in significant injury to the user, without the express written approval of NYQUEST.

Revision History

<i>Version</i>	<i>Date</i>	<i>Description</i>	<i>Modified Page</i>
1.0	2017/02/21	Formally release.	-
1.1	2017/08/31	1. Modify operation current (Iop). 2. Add NY4P005J, NY4P018J pad diagram.	10 13
1.2	2019/04/15	Modify the parameters of package dimension.	15
1.3	2021/01/27	Remove NY4P085J, NY4B075B / 85B / 95B / 105B / 115B / 125B / 145B / 165B.	-

1. 概述

NY4P系列產品為單晶片CMOS語音合成4位元微控制器，是九齊科技為了支援 NY4A, NY4B 系列MaskROM 產品所專門開發的嵌入式EPROM架構的OTP IC (One Time Programmable)。提供一通道的語音輸出，有一組高音質的PWM來直推喇叭。語音合成方式採用高音質ADPCM演算法，最高採樣率可達CD音質44.1kHz，且內建一個雜訊濾波線路可降低背景噪音。使用RISC精簡指令集架構，共有44條指令，除了少數指令需要2個時序，大多數指令都是1個時序即可完成，可以很方便的以程式控制來完成不同的應用。利用精準的 $\pm 0.5\%$ 內阻震盪，可以不需外加震盪電阻。提供待機模式(Halt mode)，可大幅度的節省功耗。

2. 功能

- 寬廣的工作電壓：2.0V ~ 5.5V。(同MaskROM IC的工作電壓範圍2.0V ~ 5.5V)
- 4-bit RISC 精簡指令集架構的微控制器，共有44條指令。
- 共有6個OTP母體，ROM容量，秒數和I/O腳數如下：

產品編號 (OTP)	語音長度 (秒) @6kHz	ROM 容量 (10-bit)	I/O 腳數
NY4P005J	5.0	16k x 10	8
NY4P018J	18.3	48k x 10	8
NY4P045J	45.0	112k x 10	8
NY4P065J	65.0	160k x 10	8
NY4P105J	105.0	256k x 10	8
NY4P165J	165.0	400k x 10	8

NY4A系列 MaskROM IC 的實際容量，秒數和I/O腳數如下：

產品編號 (MaskROM)	語音長度 (秒) @6kHz	ROM 容量 (10-bit)	I/O 腳數
NY4A003x	3.3	12k x 10	4
NY4A005x	5.0	16k x 10	4
NY4A008x	8.3	24k x 10	4
NY4A011x	11.7	32k x 10	4

NY4B系列 MaskROM IC 的實際容量，秒數和I/O腳數如下：

產品編號 (MaskROM)	語音長度 (秒) @6kHz	ROM 容量 (10-bit)	I/O 腳數
NY4B003x	3.3	12k x 10	8
NY4B005x	5.0	16k x 10	8
NY4B008x	8.3	24k x 10	8
NY4B011x	11.7	32k x 10	8
NY4B018x	18.3	48k x 10	8
NY4B025x	25.0	64k x 10	8
NY4B038x	38.3	88k x 10	8
NY4B045x	45.0	112k x 10	8
NY4B058x	58.3	136k x 10	8

NY4B065x	65.0	160k x 10	8
----------	------	-----------	---

- 96x4-bit RAM，分成2頁，每頁48x4-bit。
- 1MHz 指令頻率。
- 提供待機模式(Halt mode)，可節省功耗，靜態電流(Isb)小於1uA。
- 精準的 +/- 0.5% 內阻震盪。
- 提供低壓復位(LVR=1.8V)，看門狗計時(WDT)，I/O復位功能(External Reset)。
- 8根彈性的I/O腳，可設定為floating, pull-high, strong / weak pull-high, Reset input, IR carrier output 等輸入輸出功能。I/O可以用寄存器來作軟體控制選擇為輸入或輸出，當做為輸出時，可以選擇為一般輸出電流(Normal Drive Current) 或是大電流輸出(Large Sink Current)，可直推高亮度LED，不需外加三級管。
- IR紅外線輸出: 提供31kHz~58kHz可選擇的紅外線頻率輸出，並可選擇高電平/低電平編碼。
- 高音質ADPCM語音合成演算法，可以經由簡單的調整採樣位數來提升音質。
- 內建雜訊濾波線路(Noise-Filter)，可以適當的降低背景噪音。
- 一組9-bit PWM純硬體輸出，可以直接驅動喇叭或蜂鳴片。
- 提供大音量PWM輸出，可以直接輸出更大音量，不需外加三級管放大。
- 內建硬體的靜音壓縮演算法(Mute mode speech algorithm)，可以節省語音容量。
- 支援 Quick-IO 訊號控制。
- 提供特殊的快速燒錄模式，以加快OTP燒錄時間。
- 支援特殊的ICP (In Circuit Programming) 燒錄功能，以方便客戶先組裝PCBA模組再進行燒錄。
- 提供可程式的Code資料保護模式。(當Security-Bit 被燒斷後，資料將無法讀取。)
- 提供多種出貨型態，以滿足客戶不同的應用需求。

1. GENERAL DESCRIPTION

The NY4P series IC is a powerful 4-bit micro-controller based sound processor. They are embedded EPROM architecture, and the OTP (One Time Programmable) ICs that are designed to support NY4A and NY4B MaskROM products. There is only 1-channel speech with high quality direct-drive PWM output. By using the high fidelity ADPCM speech synthesis algorithm and a built-in noise filter, it can produce outstanding quality voices. Wide range sampling rate up to 44.1kHz is supported. The RISC MCU architecture is very easy to program and control, various applications can be easily implemented. There are 44 instructions, and most of them are executed in single cycle. Furthermore, a HALT mode (sleep mode) is designed to minimize power dissipation. Through +/- 0.5% accurate internal oscillation, external R_{osc} is unnecessary.

2. FEATURES

- Wide operating voltage range: 2.0V to 5.5V. (*Same as MaskROM products*)
- 4-bit RISC type micro-controller with 44 instructions.
- There are 6 bodies. The voice duration, ROM size and I/O counts are shown below.

Product (OTP)	Voice Duration (sec) @6kHz	ROM Size (10-bit)	I/O
NY4P005J	5.0	16k x 10	8
NY4P018J	18.3	48k x 10	8
NY4P045J	45.0	112k x 10	8
NY4P065J	65.0	160k x 10	8
NY4P105J	105.0	256k x 10	8
NY4P165J	165.0	400k x 10	8

Regarding NY4A MaskROM series, the voice duration, ROM size and I/O counts are shown below.

Product (MaskROM)	Voice Duration (sec) @6kHz	ROM Size (10-bit)	I/O
NY4A003x	3.3	12k x 10	4
NY4A005x	5.0	16k x 10	4
NY4A008x	8.3	24k x 10	4
NY4A011x	11.7	32k x 10	4

Regarding NY4B MaskROM series, the voice duration, ROM size and I/O counts are shown below.

Product (MaskROM)	Voice Duration (sec) @6kHz	ROM Size (10-bit)	I/O
NY4B003x	3.3	12k x 10	8
NY4B005x	5.0	16k x 10	8
NY4B008x	8.3	24k x 10	8
NY4B011x	11.7	32k x 10	8
NY4B018x	18.3	48k x 10	8
NY4B025x	25.0	64k x 10	8
NY4B038x	38.3	88k x 10	8

NY4B045x	45.0	112k x 10	8
NY4B058x	58.3	136k x 10	8
NY4B065x	65.0	160k x 10	8

- 96x4-bit RAM, divided into 2 pages.
- 1MHz instruction frequency.
- HALT mode to save power, less than 1uA standby current.
- Precisely embedded oscillator with build-in resistor R_{osc} (+/- 0.5%).
- Low voltage reset ($LVR=1.8V$), watch-dog reset and I/O port reset are all supported to protect the system.
- Maximum 8 flexible I/Os with optional function: floating, pull-high, strong / weak pull-high, Reset input, IR carrier output. I/O's direction is controlled by registers. For the output port, users can select the normal Drive current output or large Sink current output to directly drive high brightness LED.
- Infrared output: optional IR carrier frequency and optional data high/low IR output supported.
- New high fidelity ADPCM speech synthesis algorithm.
- Built-in noise filter for less background noise at lower volume especially.
- One 9-bit hardware PWM output.
- Support large PWM current output. *(Only for NY4B series. NY4A don't provide this function.)*
- Mute mode speech algorithm to save ROM size.
- Quick-IO control supported.
- A unique fast writing mode is provided to speed up OTP writing time.
- A special ICP (In Circuit Programming) writing function is supported for user to fabricate PCBA in advance.
- Programmable code protection is provided. *(When the Security-Bit is burnt down, data can't be read.)*
- Various shipping type for different application requirement.

3. BLOCK DIAGRAM

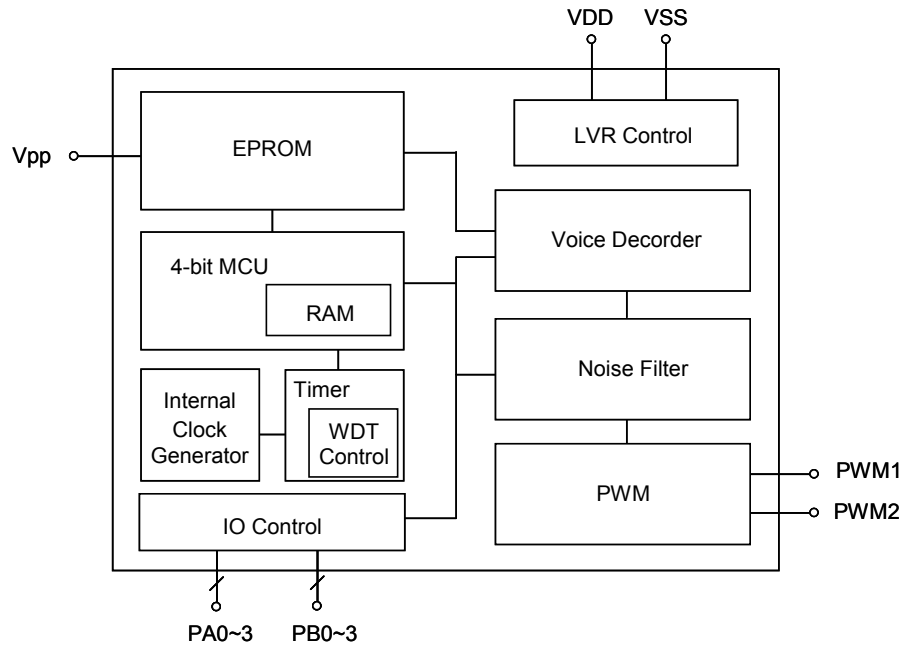

4. PAD DESCRIPTION

Pad Name	ATTR.	Description
VDD1~2	Power	Positive power.
GND1~2	Power	Negative power.
PA0/SDA	I/O	Bit 0 for Port A, or serial data input at programming mode.
PA1/SCL	I/O	Bit 1 for Port A, or serial clock input at programming mode.
PA2/IR	I/O	Bit 2 for Port A, or IR transmitter pin. (NY4A only).
PA3/Reset	I/O	Bit 3 for Port A, or external reset pin. (NY4A only).
PB0~1	I/O	Bit 0~1 for Port B.
PB2/IR/Vpp	I/O	Bit 2 for Port B, or IR transmitter pin. (NY4B only). Or positive high power for programming.
PB3/Reset	I/O	Bit 3 for Port B, or external reset pin. (NY4B only).
PWM1	O	PWM1 output.
PWM2/Mode	O	PWM2 output, or select programming mode.

5. MEMORY ORGANIZATION

There are maximum 400K words EPROM, 96 nibbles of RAM and 14 nibbles of dedicated system control register. Besides, there are several registers without address allocation, and they can only be accessed by the special instructions. One of the registers is RAM page register (PG), and the other one is 8-bit sample rate timer (TM).

5.1 ROM

A large program/data/voice single ROM is provided, and its structure is shown below. The reserved region contains system information and can't be utilized by users. The program page is limited by the unconditional branch instruction: JMP and CALL. Because it can only handle 14-bit length address of ROM, the program page size is 16K words. The PC, VPR, and RPT are 15-bit in NY4A, and 18-bit in NY4B.

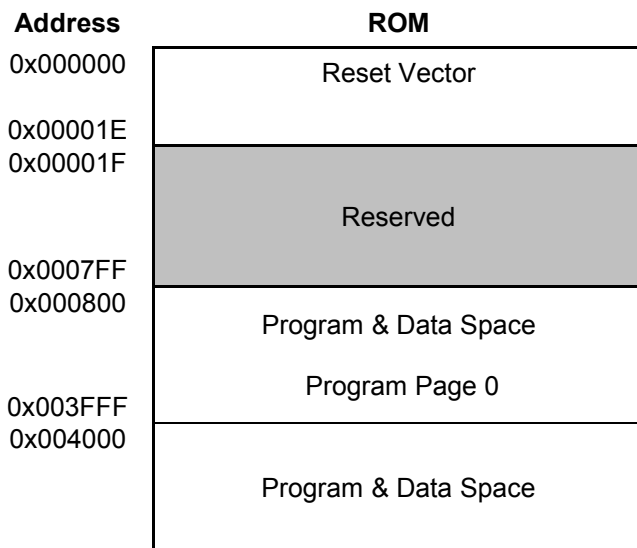

5.2 RAM

Each page of RAM contains 48 nibbles, and NY4P serial provides 96 nibbles of 2 pages. The page number (PG) register of RAM defined by the MPG instruction, and its initial value is 0. The address for RAM is 0x10~0x3F.

6. CLOCK GERERATOR

The clock generator is a Ring oscillator, and users can only select the internal resistor (INT-R). The INT-R oscillator accuracy is up to $\pm 0.5\%$.

7. IO PORTS

There are 8 I/O pins at most, designated as PAx through PBx, and x=0~3. All the I/O ports can be configured as input or output by registers. For the input port, we provide an internal pull-high register option for convenience. For the output port, users can select the large sink current output or normal drive current output.

The PA2 pin can be optioned as an infrared (IR) output pin in NY4A, and the PB2 pin can be optioned as an infrared (IR) output pin in NY4B. The PA3 pin can be optioned as an external reset pin in NY4A, and the PB3 pin can be optioned as an external reset pin in NY4B. A reset port can possess a pull-high resistor or not, and an IR port can be large sink current or normal drive current output.

The pull-high resistor of all the I/O ports has two kinds of option: weak and strong. The weak one is about 750k Ω @3V for normal application and the strong one is about 33k Ω @3V usually for key matrix function. When users configure the weak or strong pull-high resistor, the pull-high resistors of all I/O ports are set as the option value.

8. AUDIO SYNTHESIZER

There is 1-ch voice, and all modes are auto-played back by hardware. One audio output stages: 9-bit PWM is supported. The NY4 series supports 9-bit PCM and encoded ADPCM speech data. Of course, the PCM speech has higher quality and occupies more ROM space than the ADPCM one. Use the encode software provided by the Nyquest to generate the PCM or ADPCM speech data. The voice start address is loading to VPR when executing the PLAY command.

There is an option of normal PWM current or large PWM current for different customer demand. The large PWM current consumes more current and makes sound louder. *(NY4A don't support the large PWM output.)*

A Noise-Filter is built-in. When users enable this option, hardware will suppress the noise to reduce the background noise automatically. Users can also disable this option up to the sound source.

A voice channel includes a PFLG, a VPR, a voice decoder, a QIO control code generator and an 8-bit sample rate timer (TM) whose timer clock source (TCS) is fixed to 1MHz. It supports PCM and encoded ADPCM speech data.

The NY4 series supports another special mute mode for speech. When a speech like the vocal or talk has a lot of suspension or silence, using the mute mode saves much ROM space. Turn on the mute mode option of the encode software to save your cost.

9. ELECTRICAL CHARACTERISTICS

9.1 Absolute Maximum Rating

Symbol	Parameter	Rated Value	Unit
Vdd - Vss	Supply voltage	-0.5 ~ +6.0	V
Vin	Input voltage	Vss-0.3V ~ Vdd+0.3	V
Top	Operating Temperature	0 ~ +70	°C
Tst	Storage Temperature	-25 ~ +85	°C

9.2 DC Characteristics

Symbol	Parameter		VDD	Min.	Typ.	Max.	Unit	Condition
VDD	Operating voltage			2.0	3	5.5	V	1 MHz
Isb	Supply current	Halt mode	3		0.1	0.5	uA	Sleep, no load
			4.5		0.1	0.5		
Iop	Supply current	Operating mode	3		3.3		mA	1MHz, no loading
			4.5		5.3			
Iii	Input current (Internal pull-high)	Weak (750k ohms)	3		-3.7		uA	Vii=0v
			4.5		-10			
		Strong (33k ohms)	3		-67			
			4.5		-170			
Ioh	Output high current		3		-7		mA	Voh=2.0V
			4.5		-11			Voh=3.5V
Iol	Output low current (Large current)		3		17		mA	Voi=1.0V
			4.5		26			Voi=1.0V
IPWM	PWM output current (Normal)		3		60		mA	Load=8 ohms
			4.5		100			
IPWM	PWM output current (Large)		3		70		mA	Load=8 ohms
			4.5		117			
ΔF/F	Frequency deviation by voltage drop (1MHz)		3		0.1		%	$\frac{F_{osc}(3.0v) - F_{osc}(2.4v)}{F_{osc}(3v)}$
			4.5		-0.1			$\frac{F_{osc}(4.5v) - F_{osc}(3.0v)}{F_{osc}(4.5v)}$
ΔF/F	Frequency lot deviation (1MHz)		3	-0.5		0.5	%	$\frac{F_{MAX}(3.0v) - F_{TYP}(3.0v)}{F_{MAX}(3.0v)}$
Fosc	Oscillation Frequency		-	0.97	1	1.03	MHz	VDD=2.0~5.5V

9.3 Voltage vs. Frequency

Voltage vs Frequency (6.0KHz@3V)

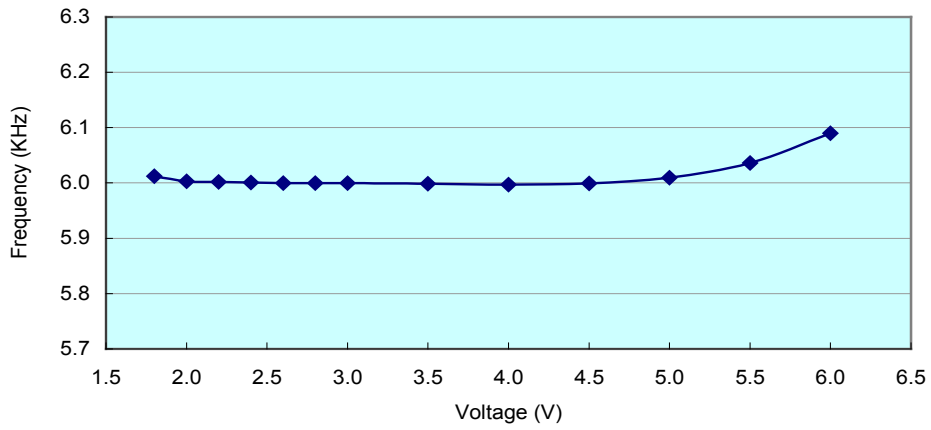

Voltage vs Freq. Deviation (6.0KHz@3V)

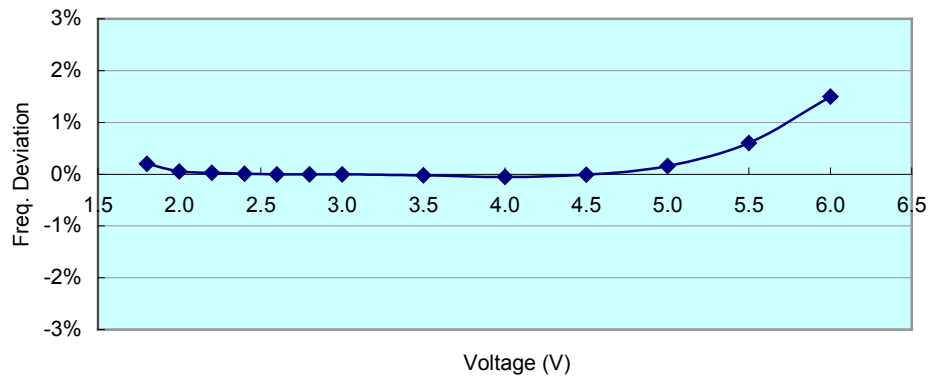

10. APPLICATION

(1) INT-R, PWM, Sink output with 4 LEDs

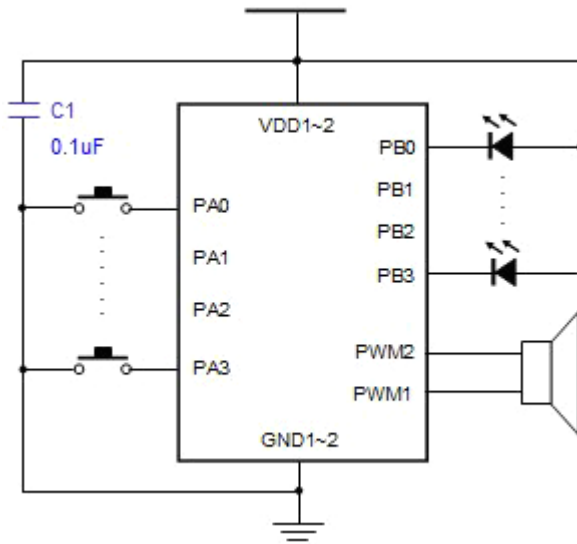

(2) INT-R, PWM, Drive output with 4 LEDs

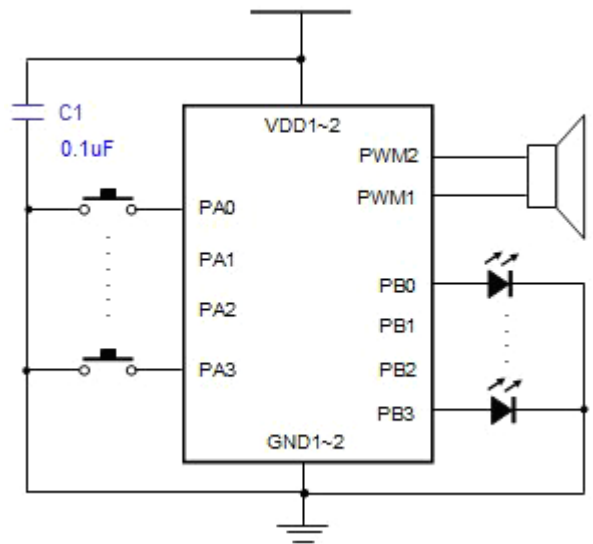

(3) INT-R, PWM, Sink output with 3 LEDs and 1 Motor

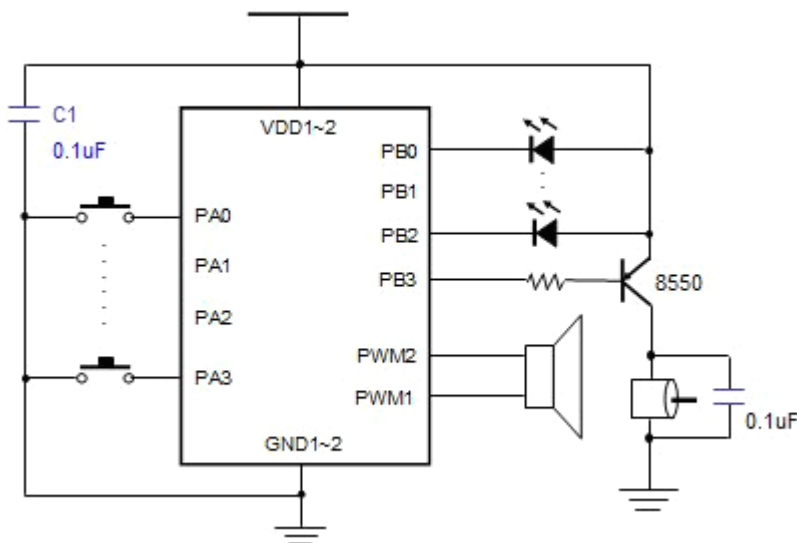

Note: C1 is VDD power cap, please **MUST** connect a 0.1uF cap between VDD and GND, or there will be noise while playing voice.

11. DIE PAD DIAGRAM

NY4P005J & NY4P018J

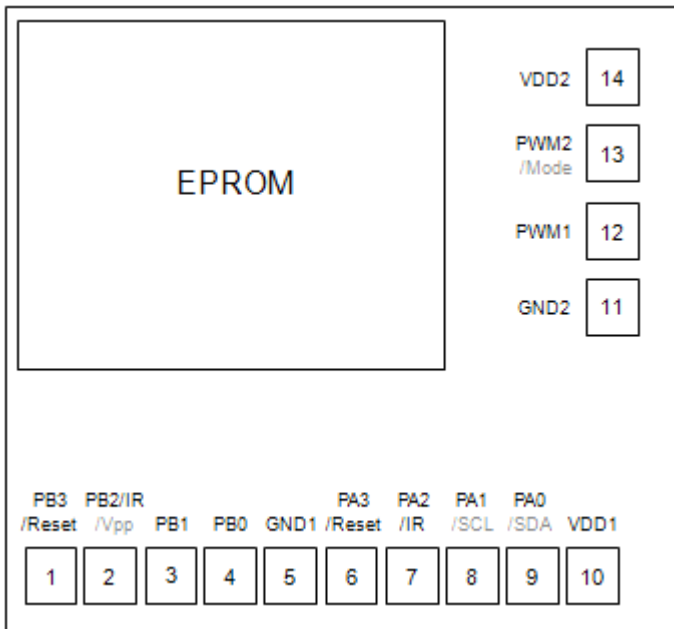

NY4P045J, NY4P065J, NY4P105J, NY4P165J

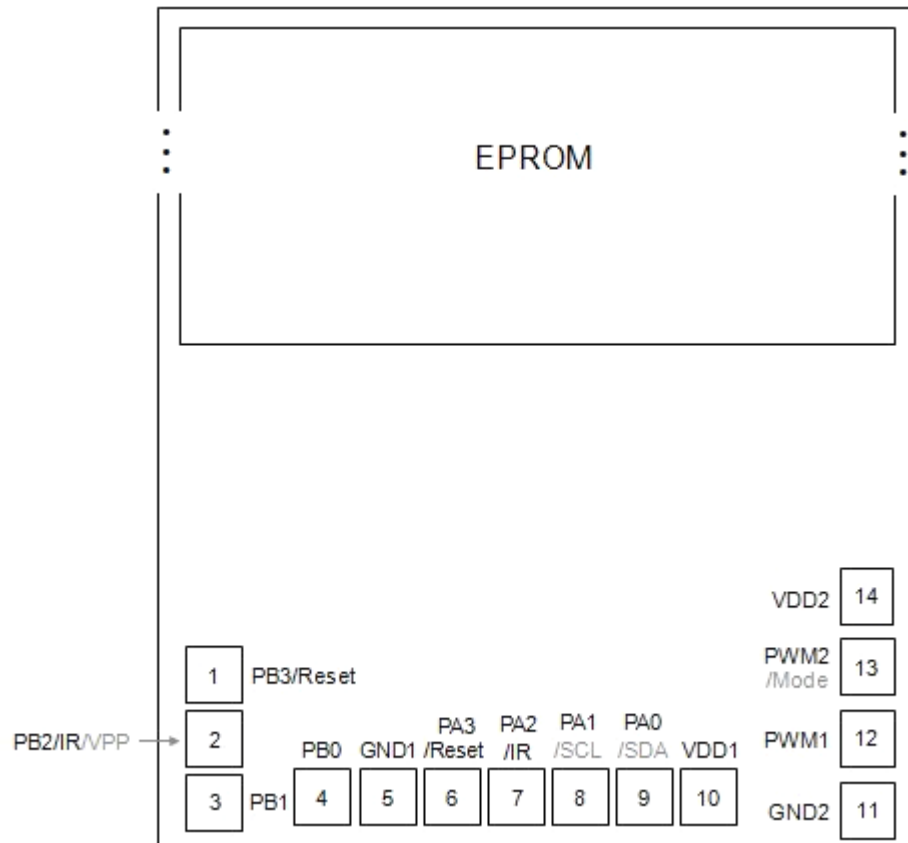

12. COB PIN ASSIGNMENT

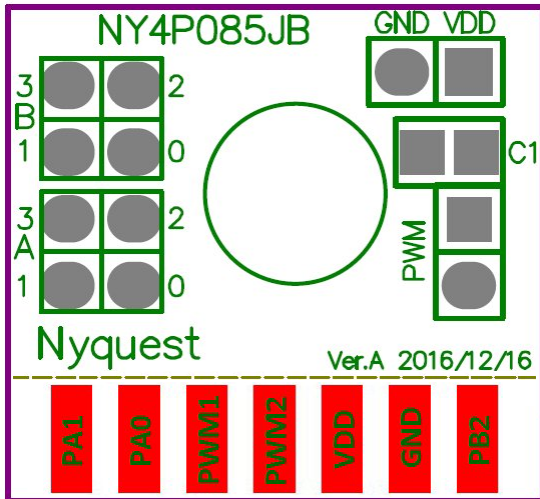

Note: C1 is VDD power cap.

13. PACKAGE PIN ASSIGNMENT

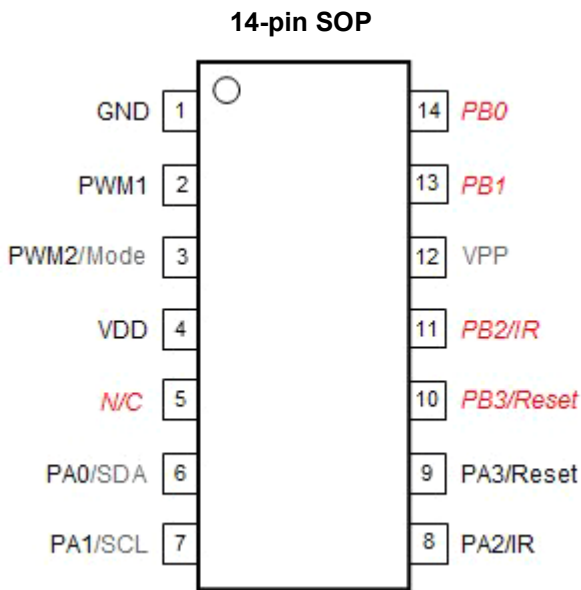

Note: The pin numbers of PB0~PB3 are different from old NY4PxxxA version.

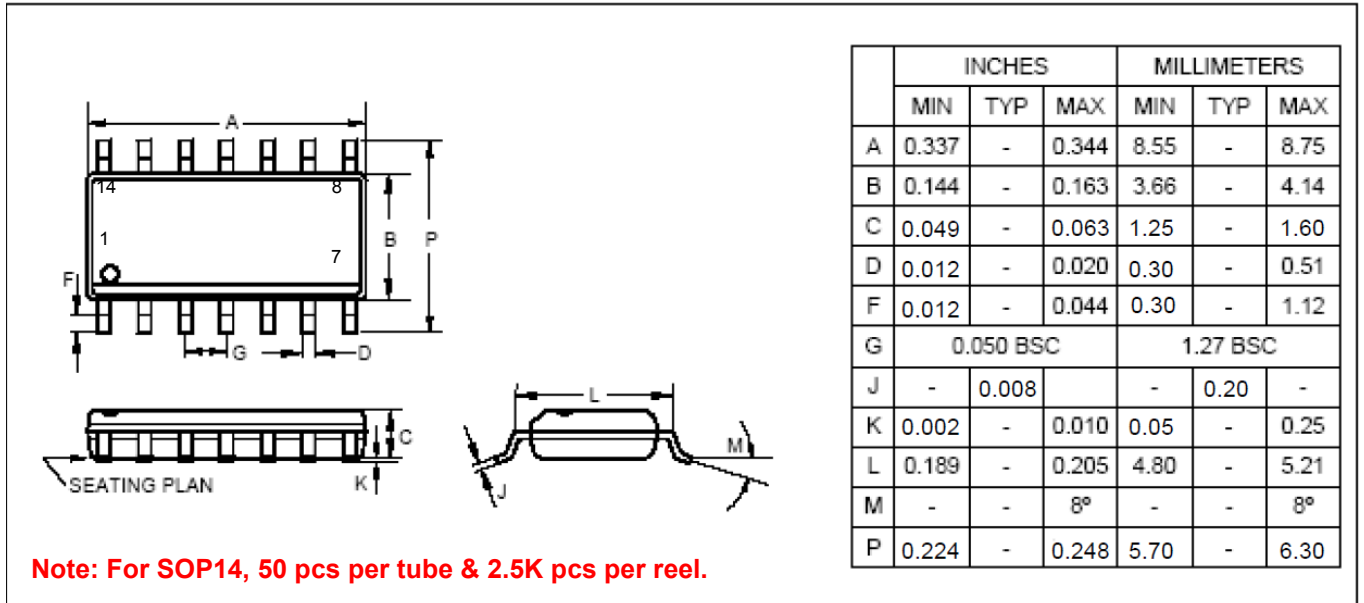
14. PACKAGE DIMENSION
14-Pin Plastic SOP (150 mil)

15. ORDERING INFORMATION

P/N	Shipping Type	Remarks
NY4P005J	Die	Empty ROM data
NY4P005J-xxxx *1	Die	Programmed ROM data
NY4P005JB	COB	20.3 mm x 14 mm (20.3 mm x 18.8 mm w/ V-Cut)
NY4P005JS14	SOP-14	Width 150 mil
NY4P018J	Die	Empty ROM data
NY4P018J-xxxx *1	Die	Programmed ROM data
NY4P018JB	COB	20.3 mm x 14 mm (20.3 mm x 18.8 mm w/ V-Cut)
NY4P018JS14	SOP-14	Width 150 mil
NY4P045J	Die	Empty ROM data
NY4P045J-xxxx *1	Die	Programmed ROM data
NY4P045JB	COB	20.3 mm x 14 mm (20.3 mm x 18.8 mm w/ V-Cut)
NY4P045JS14	SOP-14	Width 150 mil
NY4P065J	Die	Empty ROM data
NY4P065J-xxxx *1	Die	Programmed ROM data
NY4P065JB	COB	20.3 mm x 14 mm (20.3 mm x 18.8 mm w/ V-Cut)
NY4P065JS14	SOP-14	Width 150 mil
NY4P105J	Die	Empty ROM data
NY4P105J-xxxx *1	Die	Programmed ROM data
NY4P105JB	COB	20.3 mm x 14 mm (20.3 mm x 18.8 mm w/ V-Cut)
NY4P105JS14	SOP-14	Width 150 mil
NY4P165J	Die	Empty ROM data
NY4P165J-xxxx *1	Die	Programmed ROM data
NY4P165JB	COB	20.3 mm x 14 mm (20.3 mm x 18.8 mm w/ V-Cut)
NY4P165JS14	SOP-14	Width 150 mil

*1 "xxxx": Code number