



九齊科技股份有限公司
Nyquest Technology Co., Ltd.

DATA SHEET

NY9M135B

Dual Channel 1.5A/1.5A Motor Driver

Version 1.0

Aug. 17, 2018

NYQUEST TECHNOLOGY CO. reserves the right to change this document without prior notice. Information provided by NYQUEST is believed to be accurate and reliable. However, NYQUEST makes no warranty for any errors which may appear in this document. Contact NYQUEST to obtain the latest version of device specifications before placing your orders. No responsibility is assumed by NYQUEST for any infringement of patent or other rights of third parties which may result from its use. In addition, NYQUEST products are not authorized for use as critical components in life support devices/systems or aviation devices/systems, where a malfunction or failure of the product may reasonably be expected to result in significant injury to the user, without the express written approval of NYQUEST.

Revision History

<i>Version</i>	<i>Date</i>	<i>Description</i>	<i>Modified Page</i>
1.0	2018/08/17	Formal release.	-

1. 概述

NY9M135B 為單晶片 CMOS 的兩通道雙向馬達驅動 IC，利用大型積體電路 (LSI) 製造技術，具有低電源及低成本的特性，可應用於低電壓工作模式。電路採用 H 橋架構，內置功率 MOSFET 開關，可實現對直流電機做 正轉、反轉、煞車、停止 四個功能的控制。通道 1 和通道 2 的持續輸出電流為 1.5A，最大峰值輸出電流可到 2.5A。

2. 功能

- (1). 寬廣的工作電壓：1.8V ~ 6.8V。
- (2). 內置 PMOS/NMOS 功率開關的 H 橋驅動器。
- (3). 支援 4 種操作模式：正轉 / 反轉 / 剎車 / 停止。
- (4). 低待機電流 (Typ.=0.1uA)。
- (5). 通道 1 和通道 2 達到 1.5A 以上電流輸出能力。
- (6). 內建過溫保護功能。(TSD, Thermal Shutdown)
- (7). CMOS 輸入，輸入腳內建下拉電阻，無需外加限流電阻。
- (8). 高達 5KV 的人體靜電模式 (HBM) 的 ESD 保護。
- (9). 提供 ESOP-16 封裝。

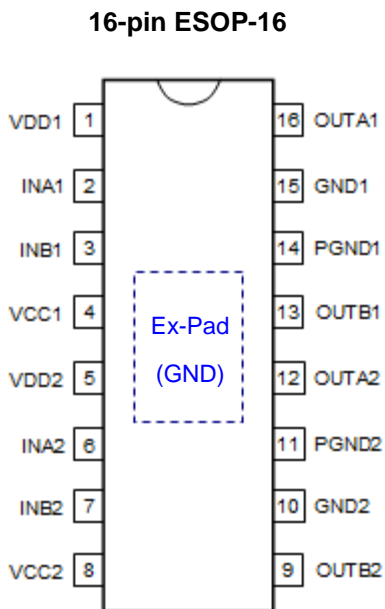

：外部焊墊。

連接到 PCB 的接地散熱片以利散熱。

1. GENERAL DESCRIPTION

NY9M135B is a single-chip dual channel bi-directional motor driver CMOS IC for low-voltage applications. It is designed by LSI high technology with a low-power and low-cost process. It has H bridge driver of built-in MOSFET power switch to provide Forward / Reverse / Brake / Stop function for motor driver applications. Both Channel 1 and Channel 2 have the same continuous current 1.5A with peak current 2.5A output capability.

2. FEATURES

- (1). Wide operating voltage: 1.8V ~ 6.8V.
- (2). H bridge driver of internal PMOS/NMOS power switches.
- (3). Support 4 operating mode: Forward / Backward / Brake / Stop.
- (4). Low standby current. (Typ.=0.1uA)
- (5). Both Channel 1 and Channel 2 have over 1.5A output current capability.
- (6). Built-in Thermal Shutdown (TSD) circuit.
- (7). CMOS input. Built-in input pull-low resistance and no current-limit resistance required.
- (8). High 5KV Human Body Mode (HBM) ESD protection.
- (9). ESOP-16 package type is available.

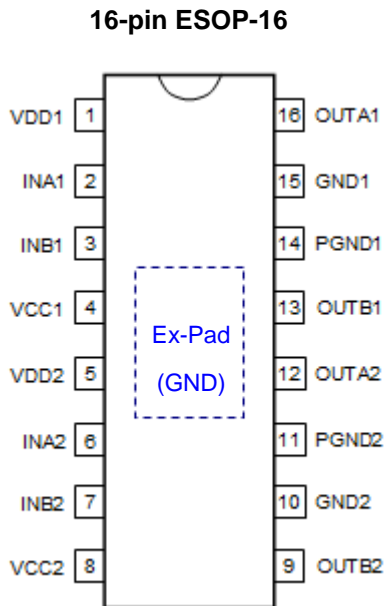

 : Exposed Pad.

Connect to PCB ground plane for heat dissipation.

3. BLOCK DIAGRAM

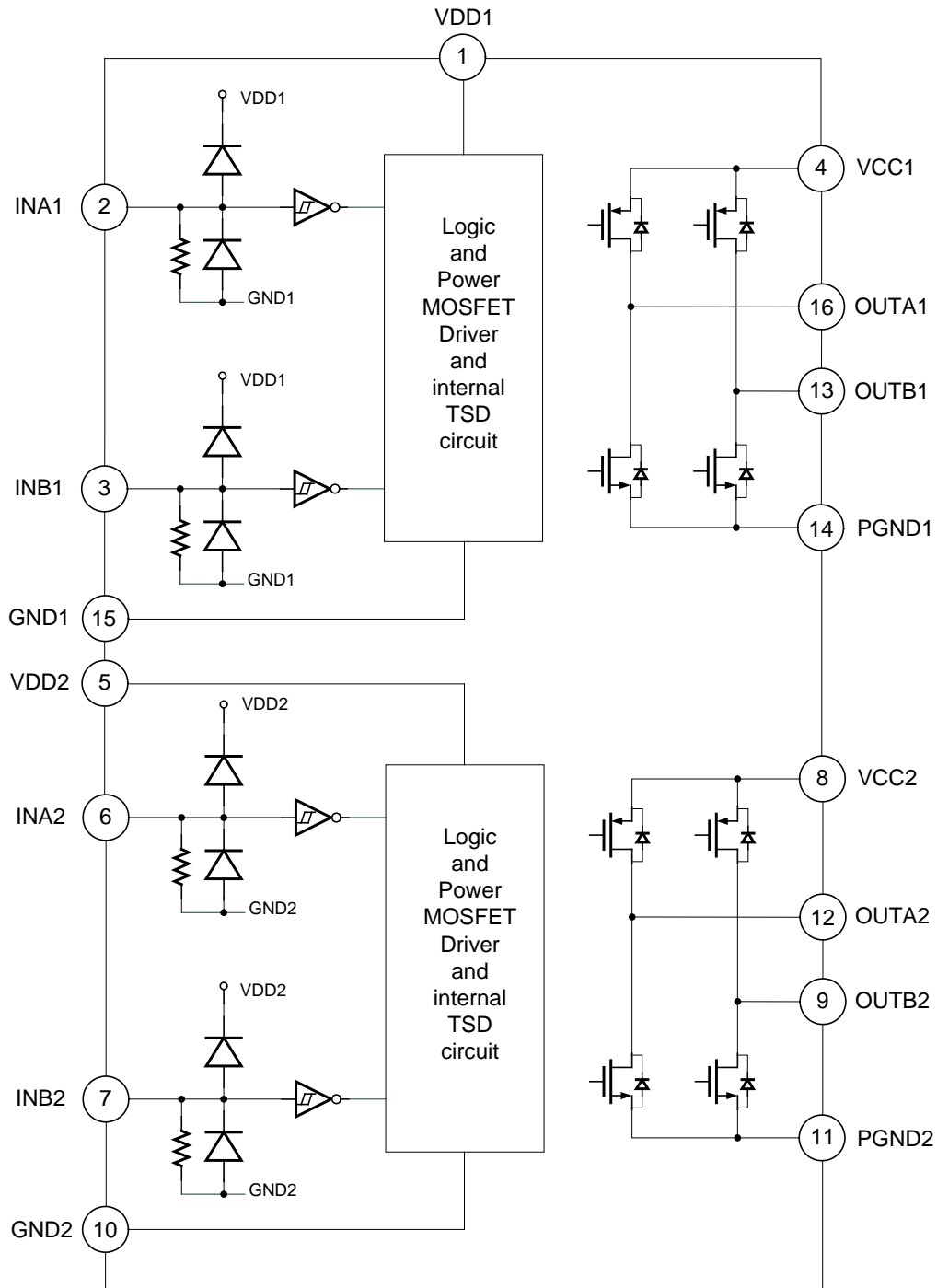

4. PIN DESCRIPTION

Pin Name	Pin No.	ATTR.	Description
INA1	2	I	Channel 1 Forward rotation logic input.
INB1	3	I	Channel 1 Backward rotation logic input.
OUTA1	16	O	Channel 1 Forward rotation output.
OUTB1	13	O	Channel 1 Backward rotation output.
VDD1	1	Power	Channel 1 Positive power of logic control circuit.
VCC1	4	Power	Channel 1 Positive power of output power MOSFET.
GND1	15	Power	Channel 1 Negative power of logic control circuit.
PGND1	14	Power	Channel 1 Negative power of output power MOSFET.
INA2	6	I	Channel 2 Forward rotation logic input.
INB2	7	I	Channel 2 Backward rotation logic input.
OUTA2	12	O	Channel 2 Forward rotation output.
OUTB2	9	O	Channel 2 Backward rotation output.
VDD2	5	Power	Channel 2 Positive power of logic control circuit.
VCC2	8	Power	Channel 2 Positive power of output power MOSFET.
GND2	10	Power	Channel 2 Negative power of logic control circuit.
PGND2	11	Power	Channel 2 Negative power of output power MOSFET.
Ex-Pad	17	Power	Exposed pad for thermal tab, must be connected to GND.

5. FUNCTION DESCRIPTION

INAx	INBx	OUTAx	OUTBx	Function
0	0	Z (Off)	Z (Off)	Stop (Standby)
1	0	1	0	Forward
0	1	0	1	Backward
1	1	0	0	Brake

x' presents value 1 or 2.

6. ELECTRICAL CHARACTERISTICS

6.1 Absolute Maximum Rating

Symbol	Parameter	Rating	Unit	
$V_{DDX} - V_{GNDX}$	Supply voltage of logic control circuit	-0.5 ~ +7.5	V	
V_{CCX}	Supply voltage of output power MOSFET	7.5	V	
$I_{OUT-PEAK}$	Output peak current	Channel 1	2.5	A
		Channel 2	2.5	
θ_{JA}	Thermal resistance (Junction to Ambient)	ESOP-16	45	°C/W
P_D	Power dissipation	ESOP-16	3	W
T_A	Operating ambient temperature		-40 ~ +85	°C
T_J	Operating junction temperature		+160	°C
T_{ST}	Storage temperature		-55 ~ +160	°C

'x' presents value 1 or 2.

6.2 DC Characteristics ($V_{DD}=3.0V$, $V_{CC}=6.0V$, $T_A=25^\circ C$, unless otherwise specified)

Symbol	Parameter	Min.	Typ.	Max.	Unit	Condition
V_{DDX}	Operating voltage (Logic)	1.8		6.8	V	
V_{CCX}	Operating voltage (MOSFET)	1.8		6.8	V	
I_{SB}	Standby current		0.1	1	uA	INAx=INBx=0
I_{OPx}	Operating current	$V_{DDX}=V_{CCX}=3.0V$		370	uA	INAx=1, INBx=0 or INAx=0, INBx=1 or INAx=1, INBx=1
		$V_{DDX}=V_{CCX}=6.0V$		650	uA	
I_{IHx}	Input high current (12kΩ pull-low resistance)		260		uA	$V_{IHx}=3.0V$
			510		uA	$V_{IHx}=6.0V$
V_{IH1}	Ch-1 input high voltage	2.0			V	
V_{IL1}	Ch-1 input low voltage			0.8	V	
V_{IH2}	Ch-2 input high voltage	2.0			V	
V_{IL2}	Ch-2 input low voltage			0.8	V	
R_{ON1}	Ch-1 output resistance		0.33		Ω	$I_{OUT}=800mA$
			0.38		Ω	$I_{OUT}=1200mA$
			0.43		Ω	$I_{OUT}=1500mA$
R_{ON2}	Ch-2 output resistance		0.33		Ω	$I_{OUT}=800mA$
			0.38		Ω	$I_{OUT}=1200mA$
			0.43		Ω	$I_{OUT}=1500mA$
I_{OUT1}	Ch-1 output continuous current (* with PCB heat dissipation)		1500	1800*	mA	ESOP-16
I_{OUT2}	Ch-2 output continuous current (* with PCB heat dissipation)		1500	1800*	mA	

Symbol	Parameter	Min.	Typ.	Max.	Unit	Condition
I _{PULSE1}	Ch-1 pulsed drain current			6.0	A	Pulse width < 20ms
I _{PULSE2}	Ch-2 pulsed drain current			6.0	A	Pulse width < 20ms
T _{RISE1}	Ch-1 output rise time		370		ns	PWM=20kHz, Duty=50%
T _{FALL1}	Ch-1 output fall time		180		ns	
T _{RP1}	Ch-1 Input-to-Output response time		570		ns	
T _{RISE2}	Ch-2 output rise time		370		ns	PWM=20kHz, Duty=50%
T _{FALL2}	Ch-2 output fall time		180		ns	
T _{RP2}	Ch-2 Input-to-Output response time		570		ns	
T _{TSD}	Thermal shutdown (TSD)		160		°C	Junction temperature
T _{TSDH}	Thermal shutdown hysteresis		40		°C	

'x' presents value 1 or 2.

7. APPLICATION CIRCUIT

(1) Two Motors Bi-Directional Control (Single Power)

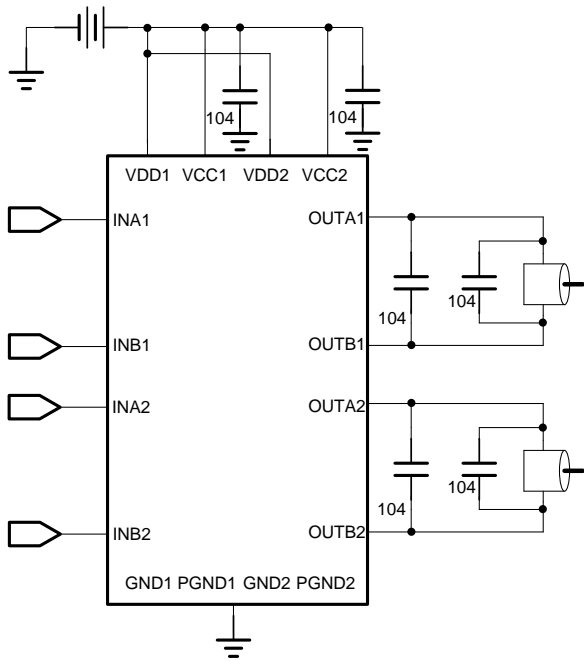

(2) Two Motors Bi-Directional Control (Dual Power)

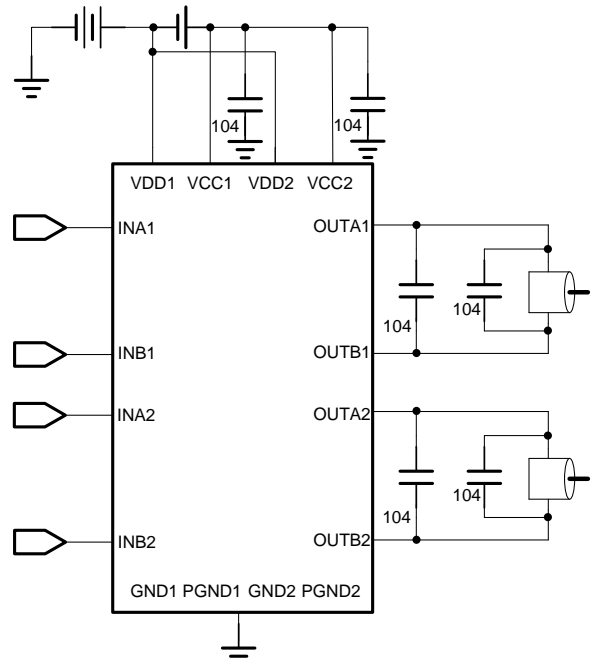

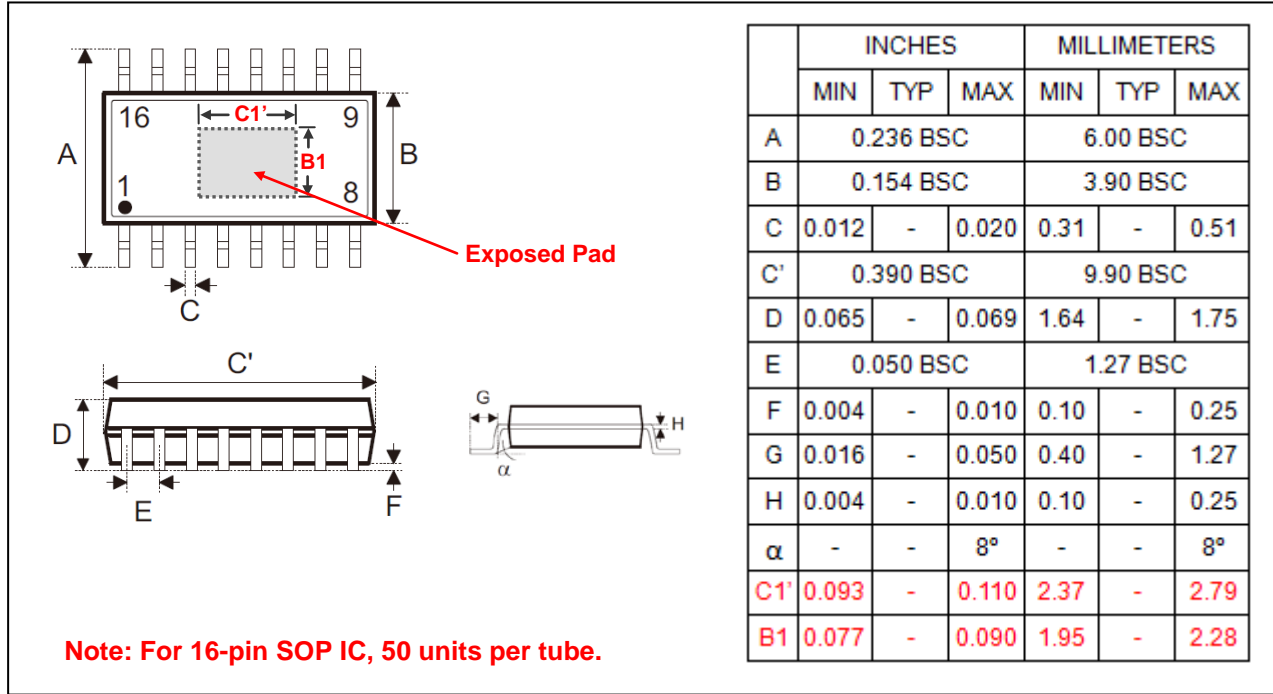
8. PACKAGE DIMENSION
16-Pin Plastic ESOP with Exposed Pad (150 mil)

9. ORDERING INFORMATION

P/N	Package Type	Package Width	Shipping
NY9M135BE16	ESOP-16	150 mil.	Tape & Reel: 2.5K pcs per Reel Tube: 50 pcs per Tube