



九齊科技股份有限公司
Nyquest Technology Co., Ltd.

DATA SHEET

NX11S2xA Series

**2-min / 4-min Voice Prompt IC in a Small
SOP-8 / SOP-16 Package**

Version 1.2

Dec. 24, 2021

NYQUEST TECHNOLOGY CO. reserves the right to change this document without prior notice. Information provided by NYQUEST is believed to be accurate and reliable. However, NYQUEST makes no warranty for any errors which may appear in this document. Contact NYQUEST to obtain the latest version of device specifications before placing your orders. No responsibility is assumed by NYQUEST for any infringement of patent or other rights of third parties which may result from its use. In addition, NYQUEST products are not authorized for use as critical components in life support devices/systems or aviation devices/systems, where a malfunction or failure of the product may reasonably be expected to result in significant injury to the user, without the express written approval of NYQUEST.

Revision History

<i>Version</i>	<i>Date</i>	<i>Description</i>	<i>Modified Page</i>
1.0	2019/11/21	<ol style="list-style-type: none">1. Add duration column for line-up.2. Remove Quad I/O mode.3. Add 4.5Kbps for SBC.	4, 7 3, 4, 6, 7, 13 5, 8
1.1	2020/06/02	Rename programming pin names to avoid confusion.	10, 20
1.2	2021/12/24	Revise I _{HALT} with typical and maximum values.	4, 7, 16

1. 概述

NX11S2xA 系列是基於 32 位元 CPU 的高品質 Speech/MIDI 處理器，特別設計成小巧的 SOP-8 / SOP-16 多晶片封裝，將 SPI Flash 合封在 MCP 內部。內嵌 OTP 作為量產晶片，完全不需要掩膜費用，並且擁有 OTP 產品在 MOQ 和交期的優勢。

CPU 內建 ILM/DLM 本地匯流排，提供每兆赫高達 1.57 DMIPS 的優異表現，當在 32MHz 最高系統頻率時，更可達到 50+ DMIPS。雙頻率設計則可讓使用者在高速與低速頻率之間切換以求取最佳的功耗/效能比。

NX11S2xA 系列包含數個產品，由內部合封 SPI Flash 記憶體大小、I/O 數目、以及封裝型態來區分。NX11S2xA 採用記憶體映射架構，可以定址到 16MB，包含記憶體 (OTP/RAM)、週邊、以及 SPI Flash 的儲存空間(支援指令/資料模式)。由於 DSP 演算法以及硬體規格的提升，NX11S2xA 支援 SBC (Sub-Band Coding, 子帶編碼)，相較於傳統式的 ADPCM 演算法，除了更高的壓縮率之外，在音質上也大幅超越傳統的語音水準！藉由 32 位元 MCU 軟體的高性能運算，可用來實現 16 和弦 MIDI。所有的資料，包括 SBC / MIDI 檔案、音色波表 (Wavetable)、XIP 程式、一般使用者資料，都可以從 SPI Flash 取得。

NX11S2xA 涵蓋了大量實用的功能：2組16位元的計時器(Timer)；14位元的數位類比轉換器 (DAC) 加上 1.3 瓦的推挽式功放可直接驅動喇叭；每根 I/O 管腳獨立控制、可作為多功能用途的 GPIO；支援 38KHz/57KHz/125KHz/500KHz 載波傳輸的紅外發射 (IR TX) 或 QFID 應用；SPI0 用來控制合封在 MCP 內部的 SPI Flash，可選擇內建的 3.3V LDO 來供電，並支援 Single/Dual I/O 模式以及 XIP (eXecute In Place, 在地執行程式) 功能。

NX11S2xA 系列除了可用 C 語言在 NYIDE 環境下開發，提供客戶更多的控制度來滿足較高複雜度的產品開發。更將高階的 Q-Code 語言移植到 32 位元 MCU，不僅提供簡單易用和高生產力的開發環境，更把握了產品構想及時實現的重要性。藉由 NX_Programmer 硬體多功能 USB 轉串列適配器，使用者可以方便地完成以下諸多事項：當作 NX1_ICE 進行程式除錯；以 NX1_FDB (Flash Demo Board) 完成原型的演示；以及使用多晶片的 SOP 封裝來量產。NX_Programmer 還提供 ICP (In-Circuit Programming) 燒寫量產板上 SPI Flash 的功能，方便客戶先組裝 PCBA 模組再進行燒錄。

NX11S2xA 系列將 SPI Flash 集成在小型的 SOP-8 / SOP-16 多晶片封裝 (MCP, Multi-Chip Package) 之中，用以滿足各式多樣化的應用。

2. 功能

- 寬廣的工作電壓：2.0V ~ 5.5V
 - SPI0 上的 SPI Flash 為寬電壓芯片，由內建 3.3V LDO 供電，可以在 1.65V ~ 3.6V 之間工作。
 - CPU 最高速度 32MHz 運行時，最低工作電壓為 3.0V；最低速度 12MHz 運行時，最低工作電壓為 2.0V。
- 32 位元 CPU 內核
 - Andes N705-S，性能相當於 ARM Cortex-M0+。
 - 最高 CPU 頻率：32MHz，搭配零等待狀態(wait-state) 的高速 OTP，可達 50+ DMIPS。
 - 單一指令週期快速乘法器。
- 共 4 個母體，SPI Flash 容量為 2Mb 和 4Mb。

P/N	RAM	OTP	I/O	Flash (Mb)	Duration (Second, SBC)		SPI0	16-bit Timer	Push-Pull	Package
					7.2Kbps	16Kbps				
NX11S21AS8	4KB	32KB	4	2	292	132	v	2	v	SOP-8, 150mil
NX11S21AS16	4KB	32KB	12	2	292	132	v	2	v	SOP-16, 150mil
NX11S22AS8	4KB	32KB	4	4	583	263	v	2	v	SOP-8, 150mil
NX11S22AS16	4KB	32KB	12	4	583	263	v	2	v	SOP-16, 150mil

Table 1 Product Line-Up of NX11S2xA Series

- 雙時脈操作，內建 HI_CLK(32MHz)和 LO_CLK(32.768KHz) 振盪器。(精準度：HI_CLK @ +/-0.5%，LO_CLK @ +/-1.5%)
- 四種工作模式可隨系統需求調整電流消耗：正常 (Normal) / 慢速 (Slow) / 待機 (Standby) / 睡眠 (Halt)，在睡眠模式下，典型耗電流 @ 1uA。
- 內建 6 階低電壓檢測器 (LVD)：3.6V, 3.4V, 3.2V, 2.6V, 2.4V, 2.2V。
- 內建低壓復位功能 (LVR)：使用者可以自行設定，預設值為 2.7V @ 32MHz, 2.4V @ 24MHz, 2.0V @ 16MHz, 1.8V @ 12MHz。
- 二組 16 位下數計時器 (Timer0 / Timer1)。
- 內建 14 位元 DAC(數位類比轉換器) 以及 1.3 瓦推挽式功放
- 最多 12 根 I/O 管腳，除了上拉電阻(以 byte 為單位)以外，每根管腳可由暫存器個別位元控制。
- 支援主模式 SPI (Master)以連接 SPI Flash 並合封於 MCP 封裝內部
 - 高達 32MHz 時脈。
 - 支援數據模式以及 XIP 模式 (在地執行程式)。
 - 支援 x1 / x2 I/O 數據模式 (Single / Dual)。
- 內建 IR 傳輸介面。
- 支援實時時鐘(RTC)：16KHz / 1KHz / 64Hz / 2Hz 中斷。
- 支援看門狗(WDT)計時：可選 188ms / 750ms 重置。

- 多晶片封裝 (MCP, Multi-Chip Package)
 - 寬電壓型 SPI Flash (1.65V ~ 3.6V) 封裝在 SOP-8 / SOP-16 內部
 - 支持 2Mb / 4Mb SPI Flash
 - SPI0 界面在封裝內部邦定，使小型封裝具備更多的 GPIO 管腳
 - 內置推挽式功放、直推喇叭
 - 最大 GPIO 管腳數：4 @ SOP-8，12 @ SOP-16
 - 可作 Master 或 Slave 操作
- 支援 OTP 安全鎖防讀寫。
- 簡易開發環境
 - 高階易用的 *Q-Code* 程式。
 - 進階的 *NYIDE C* 語言程式。
 - 多用途 NX_Programmer™ 搭配 NX1_FDB 以及 NX11S2xA 系列。
- 基於軟件的語音/MIDI 編解碼器以及各式演算法
 - ADPCM 編解碼：每採樣點 4 位元 / 5 位元。
 - SBC 編解碼：4.5K ~ 32K 比特率，最高頻寬 16KHz。
 - CELP 解碼：4.8K 比特率 (8KHz 採樣率)，僅限人聲。
 - MIDI 解碼：最多 16 通道 (32KHz 輸出採樣率)。
- 支援 4 倍頻超採樣濾波器。
- 出貨形態
 - 多芯片 MCP 封裝：SOP-8 / SOP-16。

1. GENERAL DESCRIPTION

The NX11S2xA series is a 32-bit MCU based high-quality speech/MIDI processor, which is specially designed in a small SOP-8 / SOP-16 package with SPI Flash integrated inside the MCP. It is embedded with OTP (One Time PROM) for mass production, such that no mask is required while MOQ / Lead Time are kept minimized.

With Instruction / Data Local Memory bus (ILM/DLM) built in CPU, the NX11S2xA can run 1.57 DMIPS per MHz and up to 50+ DMIPS @ 32MHz. In addition, the dual clock design let customers switch between fast / slow clocks for achieving the best power consumption and performance ratio.

The NX11S2xA series consists of several derivatives with respect to the memory size of integrated SPI Flash, I/O and package type. With memory-mapped architecture, the NX11S2xA can address up to 16MB space that includes memory, register files, peripheral and SPI Flash storage (including instruction / data modes). SBC (Sub-Band Coding) is achieved with greatly enhanced quality & much less memory size compared against traditional ADPCM coding due to the incorporation of efficient DSP algorithms as well as the upgrade of H/W spec. Via the high performance of 32-bit MCU, the S/W-based MIDI synthesizer can reach more than 16-ch polyphonic channels. All data including SBC / MIDI files, wavetable timbres, XIP codes and general user data, can be accessed from the SPI Flash integrated inside the MCP.

There are various useful features inside the NX11S2xA series: Two sets of 16-bit Timers; 14-bit DAC + 1.3-watt Push-Pull power amplifier to drive speaker directly; independently configurable GPIO per pin with alternate functions; IR TX that supports 38KHz / 57KHz / 125KHz / 500KHz carrier for Infrared or QFID applications; SPI0 for the control of the integrated SPI Flash, powered by embedded 3.3V LDO, which supports single/dual I/O mode with XIP (**eX**ecute **I**n **P**lace) capability.

Project development can be handled by C language at *NYIDE* environment, which provides customers with more controllability over complicated projects. Moreover, The NX11S2xA series brings *Q-Code* (High-level programming) to 32-bit MCU, which provides customers with an easy-to-use, highly productive development environment to cope with the importance of in-time product concept realization. The multi-purpose NX_Programmer (USB-2-Serial adaptor) H/W provides customers with various functionalities: program code debugging @ ICE, prototype demo @ NX1_FDB (Flash Demo Board) and mass production @ MCP with OTP embedded. Besides, NX_Programmer can also provide ICP (In-Circuit Programming) function to program SPI Flash for customers to fabricate PCBA in advance.

The NX11S2xA series adopts MCP technology, which integrates SPI Flash into the small SOP-8 / SOP-16 package, to meet various kinds of long-duration synthesis applications.

2. FEATURES

- Wide Operating Voltage: 2.4V ~ 5.5V
 - Wide VDD type SPI Flash @ SPI0, powered by embedded 3.3V LDO, can work from 1.65V ~ 3.6V.
 - Min. operating voltage is 3.0V @ 32MHz maximum CPU clock, and 2.0V @ 12MHz minimum CPU clock.
- 32-bit CPU core
 - Andes N705-S, like ARM Cortex-M0+.
 - Max. CPU clock: 32MHz, up to 50+ DMIPS cooperated with zero wait-state high speed OTP.
 - 1-cycle fast multiplier.
- There are 4 bodies in the NX11S2xA series. The SPI Flash size ranges from 2Mb to 4Mb.

P/N	RAM	OTP	I/O	Flash (Mb)	Duration (Second, SBC)		SPI0	16-bit Timer	Push-Pull	Package
					7.2Kbps	16Kbps				
NX11S21AS8	4KB	32KB	4	2	292	132	v	2	v	SOP-8, 150mil
NX11S21AS16	4KB	32KB	12	2	292	132	v	2	v	SOP-16, 150mil
NX11S22AS8	4KB	32KB	4	4	583	263	v	2	v	SOP-8, 150mil
NX11S22AS16	4KB	32KB	12	4	583	263	v	2	v	SOP-16, 150mil

Table 1 Product Line-Up of NX11S2xA Series

- Dual Clock Operation. Built-in oscillators for HI_CLK (32MHz) and LO_CLK (32.768KHz), accuracy trimmed to +/-0.5% for HI_CLK and +/-1.5% for LO_CLK.
- Power management to support 4 operating modes: Normal / Slow / Standby / Halt mode. At Halt mode, the typical consumption current is 1uA.
- LVD (Low Voltage Detection): Total 6-level options: 3.6V, 3.4V, 3.2V, 2.6V, 2.4V, 2.2V.
- LVR (Low Voltage Reset): User-configurable, default values are 2.7V @ 32MHz, 2.4V @ 24MHz, 2.0V @ 16MHz, 1.8V @ 12MHz.
- Timers (Timer0 / Timer1): Each Timer consists of divider and 16-bit down-counter with various clock sources.
- Built-in 14-bit DAC + 1.3-Watt Push-Pull power amplifier
- Up to 12 pins GPIO. Bit configurability for every I/O pin by register control, except pull-up value by byte.
- SPI master supported to connect with the SPI Flash integrated inside MCP
 - Up to 32MHz clock speed.
 - Support Data mode and XIP mode (eXecute In Place).
 - Support Single / Dual I/O mode of SPI Flash.
- IR TX supported.
- RTC with 16KHz / 1KHz / 64Hz / 2Hz interrupts.

- WDT (Watch-Dog Timer) supported with optional 188ms / 750ms Reset.
- MCP (Multi-Chip Package)
 - Wide VDD type SPI Flash (1.65V ~ 3.6V) packaged inside SOP-8 / SOP-16
 - Support 2Mb / 4Mb SPI Flash density
 - SPI0 interface bonded inside the package, leaving more GPIO pins available
 - Built-in Push-Pull PA to drive speaker directly
 - Max. GPIO pins: 4 @ SOP-8, 12 @ SOP-16
 - Master or Slave operation
- Support OTP Security Lock to prevent OTP data from being read.
- Easy-to-use Development Environment
 - High-level Q-Code programming.
 - *NYIDE* for advanced programming with C language.
 - Multi-purpose NX_Programmer™ to work with NX1_FDB and NX11S2xA series.
- S/W-based Speech/MIDI Codec & various algorithms
 - ADPCM Codec (Adaptive Differential PCM): 4-bit / 5-bit per sample.
 - SBC Codec (Sub-Band Coding): 4.5K ~ 32Kbps with maximum 16KHz bandwidth.
 - CELP Decoder (Code-Excitation Linear Prediction): 4.8Kbps @ 8KHz SR for human voice only.
 - MIDI: Up to 16-channel MIDI @ 32KHz Output Sample Rate.
- Noise filter @ 4x Up-Sampling.
- Shipping Form
 - MCP (Multi-Chip Package): SOP-8 / SOP-16.

3. BLOCK DIAGRAM

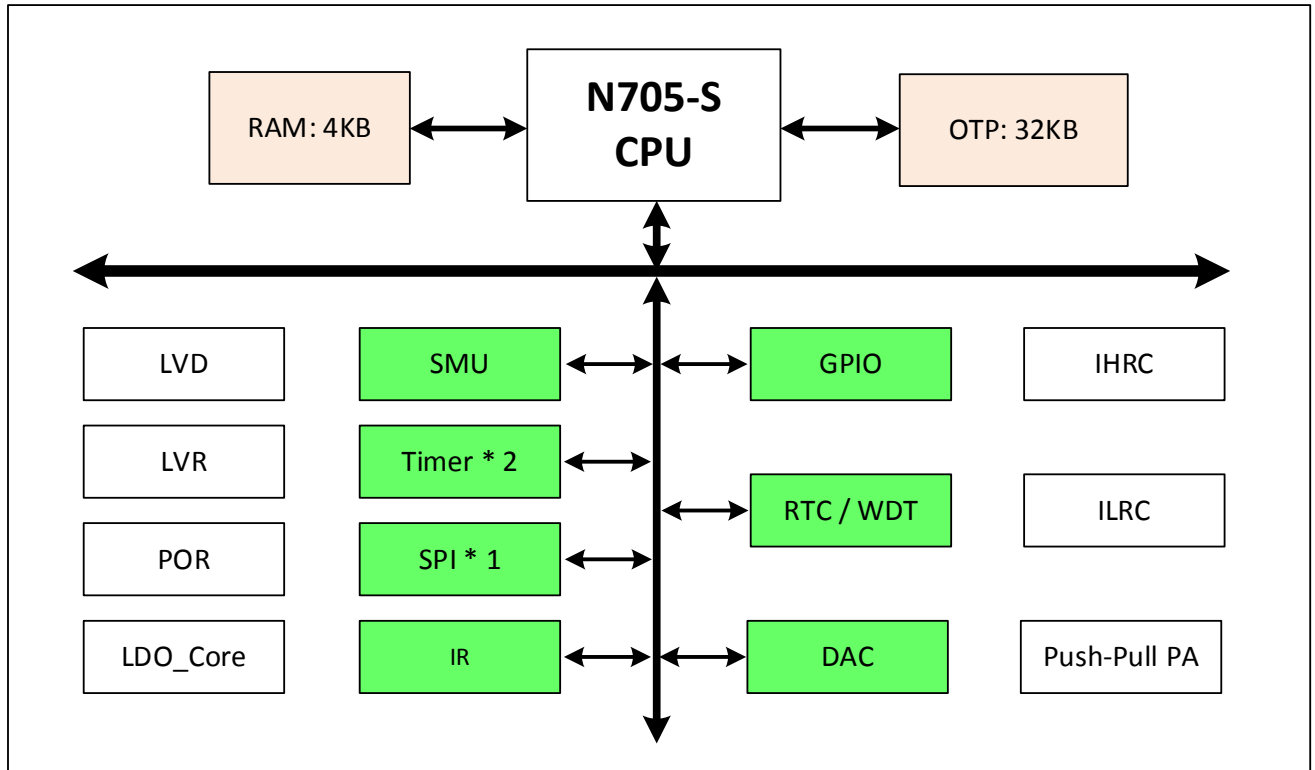

Figure 1 Block Diagram of NX11S2xA Series

4. PAD DESCRIPTION

Name	ALT 1	Type	Description
Power & Ground			
VDD	-	P, I	Power input
VSS	-	P, I	Ground
PP / DAC			
PP1	DAC0	AO	Push-Pull PA output 1 or DAC0
PP2	-	AO	Push-Pull PA output 2
Port A			
PA0	-	I/O	PA0 or Analog input 0
PA1	-	I/O	PA1 or Analog input 1
PA2/Vpp	RSTb	I/O I/P	PA2/Vpp (only for OTP / SPI Flash programming), or RSTb pin
PA3/SCK	-	I/O	PA3/Programming Clock
PA4/MOSI	TM0	I/O, I	PA4/Programming Input, or Timer input 0
PA5/MISO	IR	I/O, O	PA5/Programming Output, or IR output
PA6	-	I/O, O	PA6
PA7	-	I/O, I	PA7
PA8	-	I/O	PA8
PA9	-	I/O	PA9
PA10	-	I/O	PA10
PA11	-	I/O	PA11
Port B (specifically for SPI Flash stacked inside MCP)			
PB0	SPI0_CSb	O	SPI0's CSb
PB1	SPI0_SCK	O	SPI0's SCK
PB2	SPI0_IO0	I/O	SPI0's IO0 (MOSI)
PB3	SPI0_IO1	I/O	SPI0's IO1 (MISO)
PB4	SPI0_IO2	I/O	SPI0's IO2
PB5	SPI0_IO3	I/O	SPI0's IO3

Pad Type: P = Digital Power, I = Digital Input, O = Digital Output, AI = Analog Input, AO = Analog output, AP=Analog Power.

5. MEMORY ORGANIZATION

The memory map of the NX11S2xA series is depicted in Figure 2 Memory Map of the NX11S2xA Series. The OTP ROM, RAM, function registers, and interrupt vectors, are all memory mapped. The OTP size is 32KB, while the RAM size is 4KB. Total addressing space is 16MB, while SPI Flash is mapped within 0x80_0000 ~ 0x9F_FFFF (2MB space) for XIP and data storage purposes.

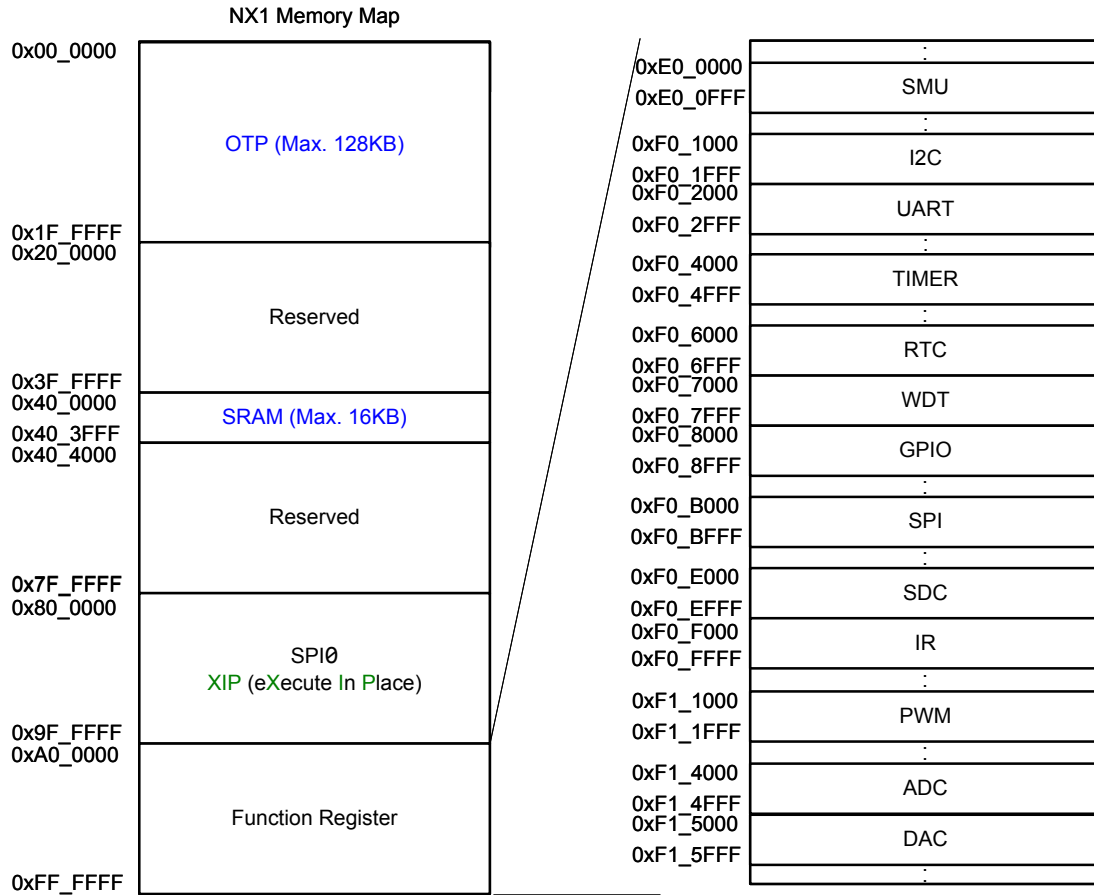

Figure 2 Memory Map of the NX11S2xA Series

6. CLOCK GENERATOR

The clock generator consists of 2 clock sources:

- Built-in high clock (I_HRC): Output frequency can be 32MHz, 24MHz, 16MHz, or 12MHz by option.
- Built-in low clock (I_LRC): Output frequency is 32,768Hz.

The internal oscillators, I_HRC and I_LRC, are trimmed to achieve +/-0.5% and +/-1.5% accuracy, respectively.

7. OPERATING MODE

The NX11S2xA series provides four kinds of operating modes to tailor for various kinds of applications while saving power consumption. These operating modes are normal mode, slow mode, standby mode and halt mode.

Normal mode is designated for high-speed, high-performance operation, while slow mode is designated for low-speed operation to save power consumption. At standby mode, the NX11S2xA series will stop almost all operations, except peripheral blocks with clock source from LO_CLK, to wake-up periodically. At halt mode, the NX11S2xA series will stop all operations, waiting for external events to wake it up.

When the NX11S2xA is power up, there is a delay of 32mS before user's code is executed to ensure the proper operation. Besides, the SPI Flash needs another 15mS to get power stabilized after SPI0_VDD is turned on. Therefore, there is a total of 50mS or so before any attempt to access the data stored inside the SPI Flash.

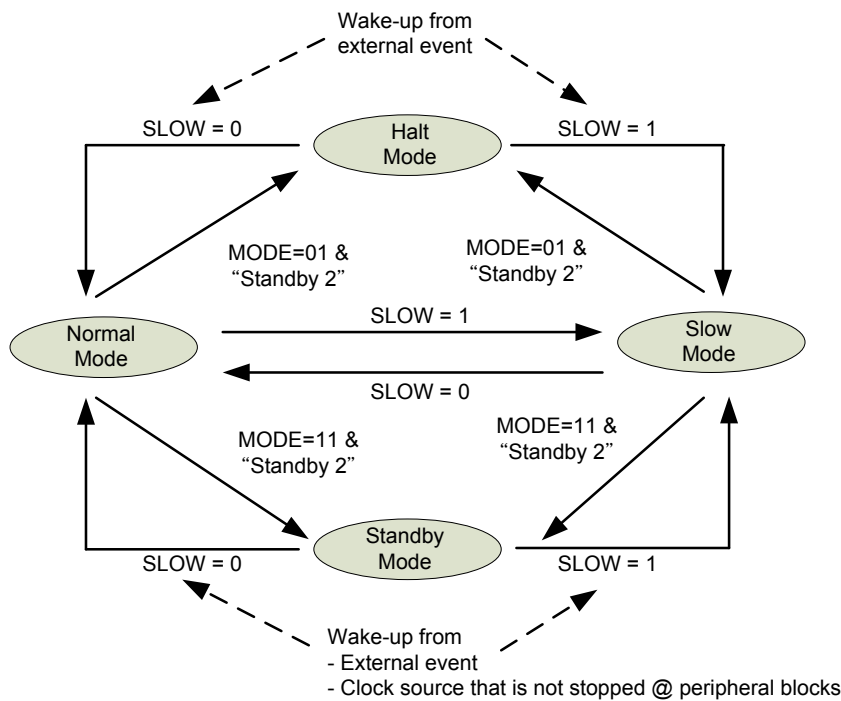

Figure 3 Four Operating Modes

8. INTERRUPT

Interrupt signals are directly connected to the N705-S processor. The interrupt priority is controlled by the processor. Each interrupt is assigned with 2 bits to represent 4 possible priority levels ranging from 0 (highest) to 3 (lowest). The hardware compares the priority level first: the smaller the priority level, the higher the priority. With the same priority, the lower the interrupt number, the higher the priority.

9. PERIPHERALS

9.1 I/O Port

Up to 12 * I/O pins are available, since PB0 ~ PB5 are dedicated to interface with the stacked SPI Flash. These are shared multiple function pins under control of the alternate multiple function registers. These 12 * I/O pins belong to Port A (PA0 ~ PA11).

Each pin can be configured as input or output, weak / strong pull-high resistor and can generate interrupt signal to CPU.

9.2 SPI0

The SPI0 is dedicated for connecting with the SPI Flash packaged inside the MCP to store most of the data used for various applications like speech (ADPCM, SBC, or CELP), melody (including MIDI file and wavetable timbres), user's general data storage. With single/dual I/O modes supported, the SPI Flash can run up to 32MHz clock. Together with the XIP capability (eXecute In Place), users can extend the program code to the SPI Flash at a descent performance for many applications.

The SPI Flash is a wide VDD type, which can operate under 1.65V ~ 3.6V. Under low voltage conditions, like 2-battery applications, the embedded 3.3V SPI0_VDD that is used to power the SPI Flash would drop accordingly with the battery voltage, while continuing to work down to 2.0V @ 12MHz.

Due to the limitation of the SPI Flash architecture, each page (256 bytes) can not be written over 8 times per erasure. Although it's no problem for most applications that simply erase the whole chip and re-programmed entirely of the SPI Flash space, users who may write data onto the SPI Flash should avoid the above-mentioned page writing times after each erasure.

9.7 IR TX

The NX11S2xA provide a 5-bit IR carrier, it can generate different IR frequency by assign different counter value.

- Support output stop at 0 or 1.
- Support 5 bits reload data to adjust IR's frequency.

10. TIMER

The NX11S2xA has two 16-bit timers: TIMER0 / TIMER1, which can be used as a trigger source for or as a function of time delay, clock generation, etc.

- Programmable source of timer clock
- 16-bit counter for each timer

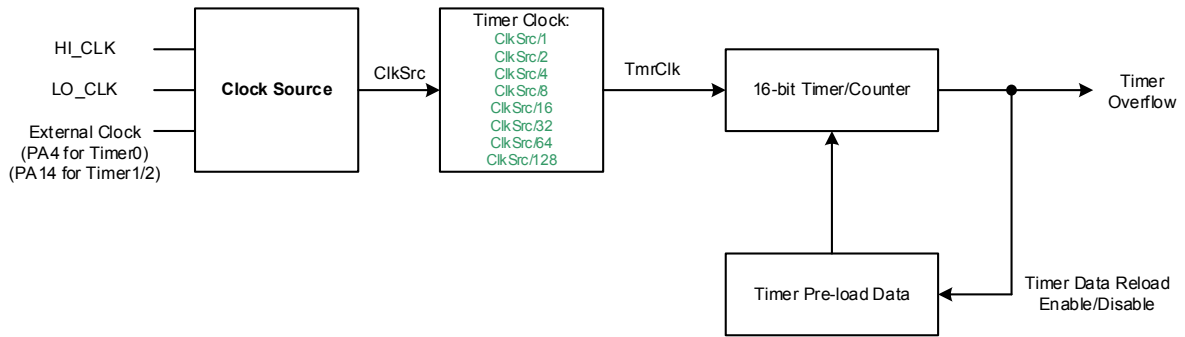

Figure 4 Timer Block Diagram

11. RTC

As the name implies, the RTC (Real-Time Clock) is generally used to keep the time, with the clock source from either an internal built-in I_LRC (trimmed to 32,768Hz with +/-1.5% accuracy), or an external crystal (32,768Hz). The RTC support periodic time tick interrupts with 4 options: 16KHz, 1KHz, 64Hz, 2Hz.

12. WDT

The Watchdog Timer (WDT) is used to perform a system reset when the system is not responding. There are two period options for the WDT to generate a reset: 188ms / 750ms.

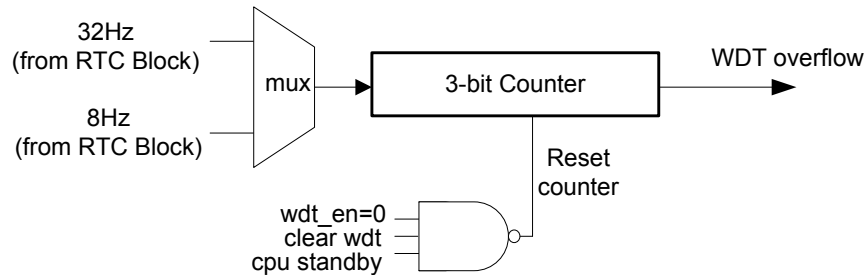

Figure 5 WDT Block Diagram

15. DAC & PP

The NX11S2xA provides two data buffers with 8-level FIFO each and up to two 14-bit Digital-to-Analog converters (optional) with interpolation function. It can be started by software or TIMER trigger.

- Provide 8-level FIFO per channel data buffer
- Provide hardware up-sampling (interpolation) function
- Support mixing mode for two-channel data applications

16. LVD

The LVD (Low Voltage Detector) is trimmed to +/-0.1V accuracy for the user to detect the battery voltage @ VDD pin. When the VDD voltage falls below the specified LVD level, the LVD_Flag will be set as HIGH.

LVD_SEL[2:0]	Voltage
111	<i>Reserved</i>
110	<i>Reserved</i>
101	3.6V
100	3.4V
011	3.2V
010	2.6V
001	2.4V
000	2.2V

Table 2 LVD voltage select

17. OPTIONS

Users may select different options depending on the application requirement. There are several options that users may select for the NX11S2xA series, as shown in Table 3 User Options.

Item	Name	Options
1	High Oscillation Source	1. I_HRC 2. E_HXT
2	Low Oscillation Source	1. I_LRC 2. E_LXT
3	HI_CLK Frequency	1. 32MHz (Core LDO @ 3.3V) 2. 24MHz (Core LDO @ 2.8V) 3. 16MHz (Core LDO @ 2.5V) 4. 12MHz (Core LDO @ 2.5V)
4	VDD Voltage	1. 4.5V 2. 3.0V
5	SPI0_VDD Voltage	1. 3.3V (fixed for NX11S2xA series)
6	LVR Voltage	1. 2.9V / 2.8V / <u>2.7V</u> / 2.6V / 2.5V (HI_CLK @ 32MHz) 2. 2.6V / 2.5V / <u>2.4V</u> / 2.3V / 2.2V (HI_CLK @ 24MHz) 3. 2.2V / 2.1V / <u>2.0V</u> / 1.9V / 1.8V (HI_CLK @ 16MHz) 4. 2.0V / 1.9V / <u>1.8V</u> / 1.7V / 1.6V (HI_CLK @ 12MHz)

Table 3 User Options

18. ELECTRICAL CHARACTERISTICS
18.1 Absolute Maximum Rating

Symbol	Parameter	Rated Value	Unit
$V_{DD} - V_{SS}$	Supply voltage	-0.5 ~ +7.5	V
V_{IN}	Input voltage	$V_{SS} - 0.3 \sim V_{DD} + 0.3$	V
T_{OP}	Operating Temperature	0 ~ +70	°C
T_{ST}	Storage Temperature	-25 ~ +85	°C

18.2 DC Characteristics ($T_A=25^\circ\text{C}$, unless otherwise specified)

Symbol	Parameter		V_{DD}	Min.	Typ.	Max.	Unit	Condition
V_{DD}	Operating voltage		-	3.0	4.5	5.5	V	CPU_CLK=32MHz
				2.7	4.5	5.5		CPU_CLK=24MHz
				2.2	3.0	5.5		CPU_CLK=16MHz
				2.0	3.0	5.5		CPU_CLK=12MHz
				2.0	3.0	5.5		CPU_CLK=32.768KHz
I_{HALT}	Halt Current		3		1		uA	CPU stop, all functions off
			4.5		1			
I_{SB}	Standby Current		3		3		uA	CPU stop, all functions off, RTC on
			4.5		3			
I_{OP}	Operating Current	Slow Mode	3		58.3		uA	CPU_CLK=32.768KHz
				4.5		75		
		Normal Mode	3		6.1		mA	CPU_CLK = 12MHz, Core_LDO = 2.3V
					7.5			CPU_CLK = 16MHz, Core_LDO = 2.3V
				4.5		12.0		
4.5		19.1		CPU_CLK = 32MHz, Core_LDO = 3.3V				
I_{IL}	Input current (Internal pull-high)	Weak (1M Ω)	3		-2.7		uA	$V_{IL} = 0V$
			4.5		-7.2			
		Strong (100K Ω)	3		-30			
			4.5		-78			
		SDC pad (20K Ω)	3		-144			
			4.5		-215			

Symbol	Parameter	V _{DD}	Min.	Typ.	Max.	Unit	Condition
I _{OH}	Normal drive current (PA)	3		-8.7		mA	V _{OH} = 2.0V
		4.5		-13.7			V _{OH} = 3.5V
	Normal drive current (PB for SPI0)	3		-12.9			V _{OH} = 2.0V
		4.5		-20.2			V _{OH} = 3.5V
	Large drive current (PB for SPI0)	3		-24.8			V _{OH} = 2.0V
		4.5		-38.0			V _{OH} = 3.5V
I _{OL}	Normal sink current	3		12.4		mA	V _{OL} = 1.0V
		4.5		19.2			
	Large sink current	3		24.3			
		4.5		37.1			
I _{PP}	Push-Pull Output Current	3		180		mA	Load = 8 Ω
		4.5		280			
ΔF/F	Frequency deviation by voltage drop (I _{HRC} =32MHz/24MHz)	4.5		-0.5		%	$\frac{F_{osc}(4.5v) - F_{osc}(3.3v)}{F_{osc}(4.5v)}$
	Frequency deviation by voltage drop (I _{HRC} =16MHz/12MHz)	3		-0.5			$\frac{F_{osc}(3.0v) - F_{osc}(2.4v)}{F_{osc}(3.0v)}$
		4.5		-0.5			$\frac{F_{osc}(4.5v) - F_{osc}(3.0v)}{F_{osc}(4.5v)}$
ΔF/F	Frequency deviation by lot	3	-0.5		0.5	%	$\frac{F_{osc}(3.0v) - F_{typ}(3.0v)}{F_{typ}(3.0v)}$

18.3 DAC Characteristics

Symbol	Characteristics	Min.	Typ.	Max.	Unit	Condition
B _{RES}	Resolution of DAC			14	Bit	-
DR	Dynamic Range (V _{in} = -60 dBFS)		-73		dBr A	No Load
SNR	Noise at No Signal (V _{in} = -90 dBFS)		-97		dBr A	
P _O	THD+N 1%		0.7		W	4Ω Load
	THD+N 10%		1.3		W	

18.4 Voltage vs. Frequency

18.4.1 I_HRC @ 32 MHz

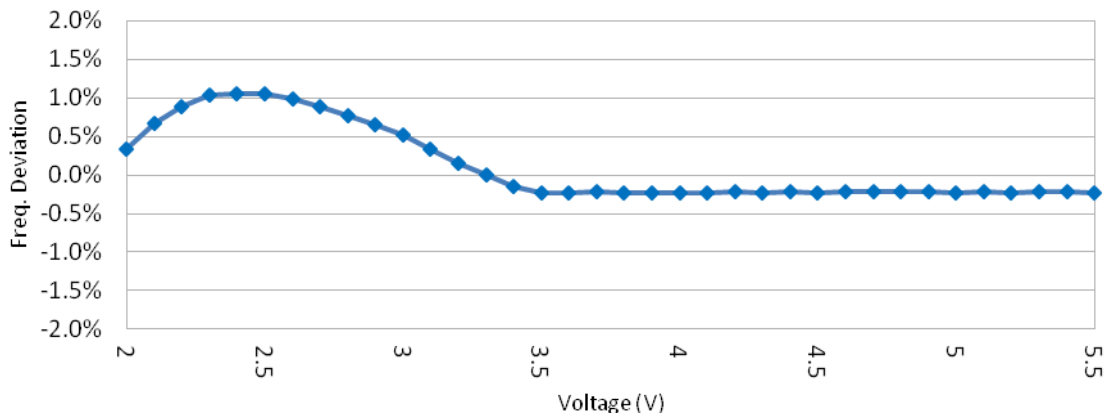

18.4.2 I_HRC @ 24 MHz

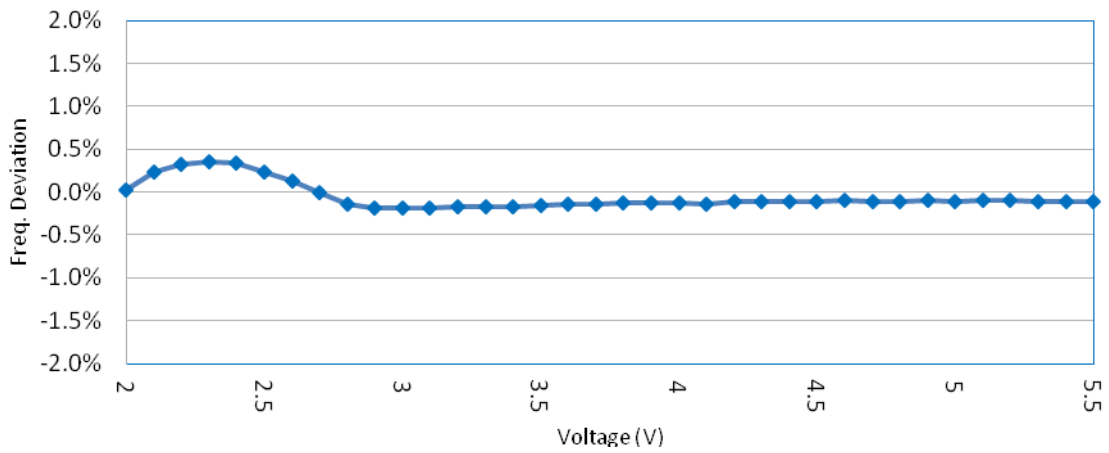

18.4.3 I_HRC @ 16 MHz

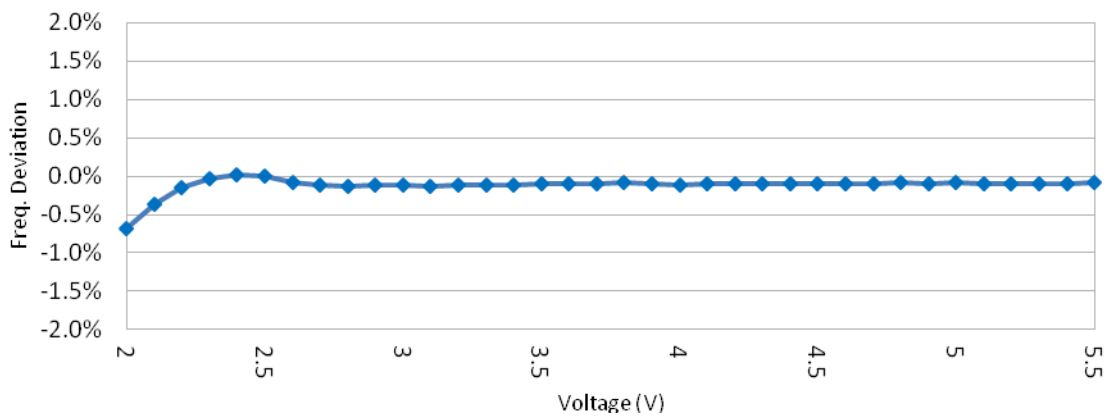

18.4.4 I_HRC @ 12 MHz

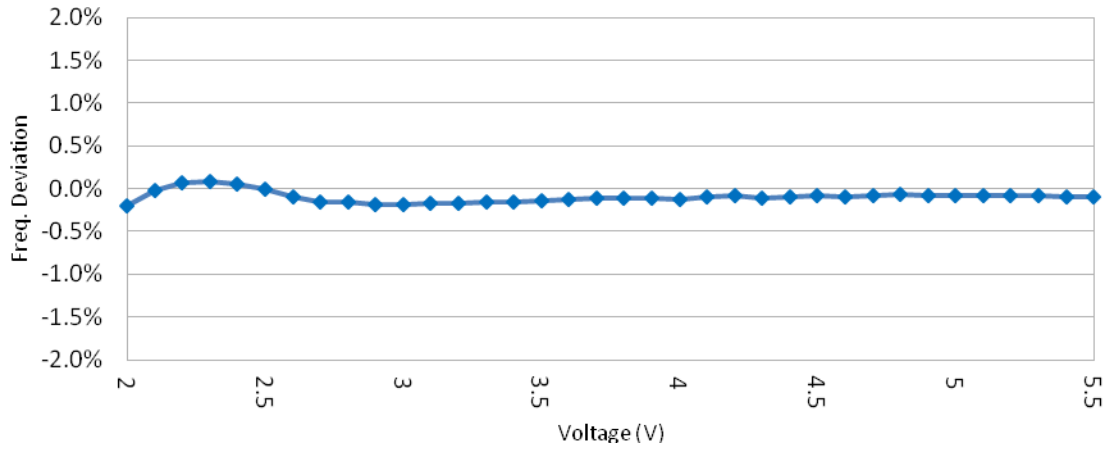

18.4.5 I_LRC @ 32 KHz

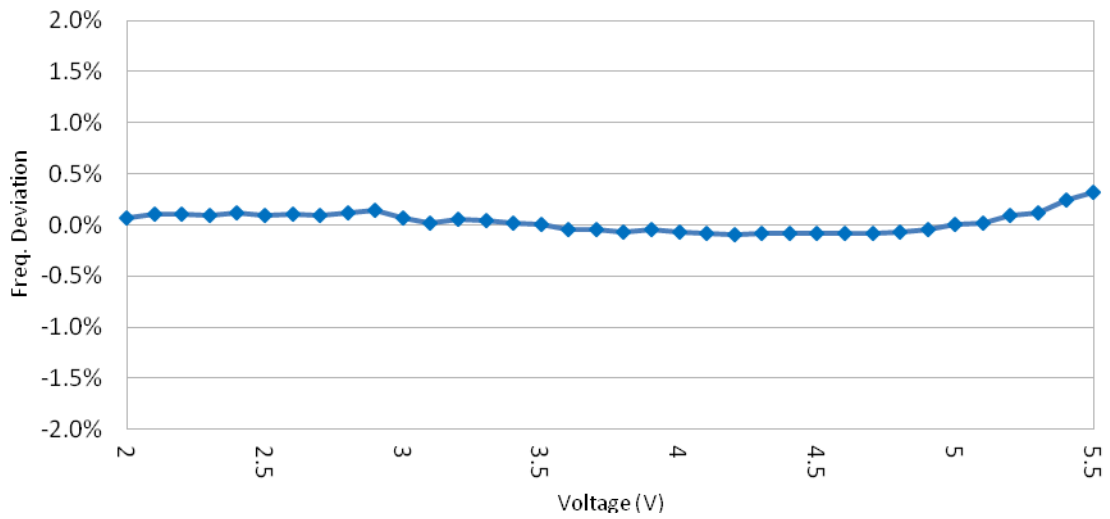

19. APPLICATION

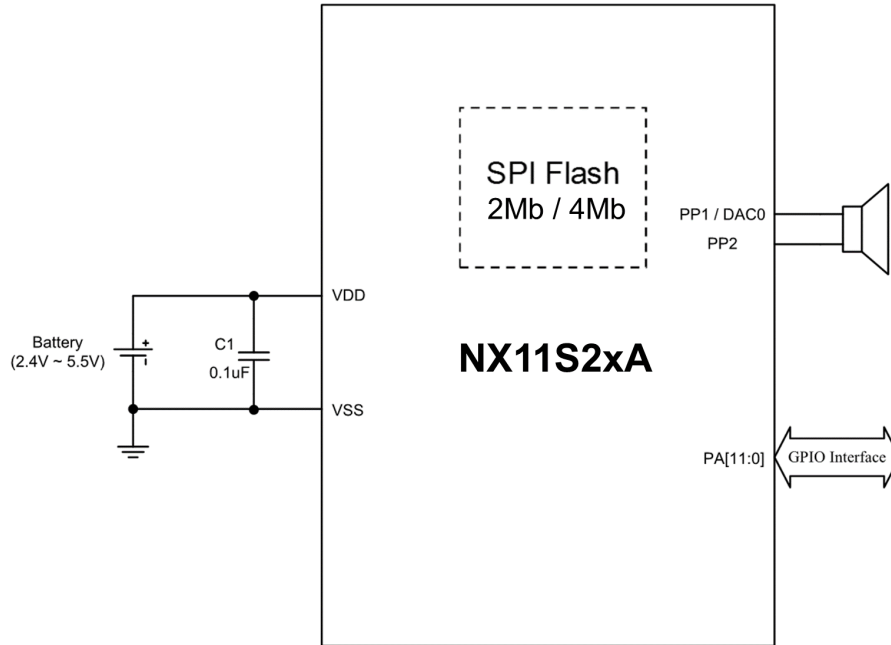

20. PACKAGE PIN ASSIGNMENT

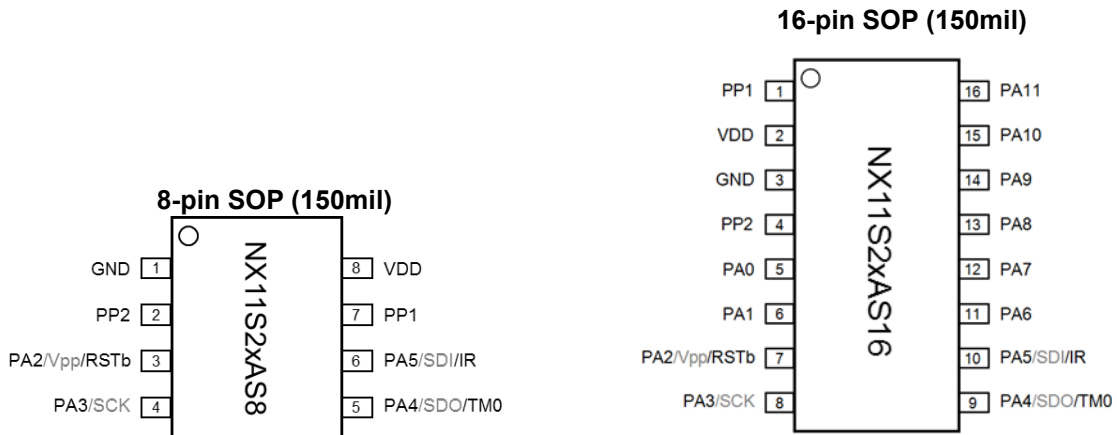

21. PACKAGE DIMENSION

21.1 8-Pin Plastic SOP (150 mil)

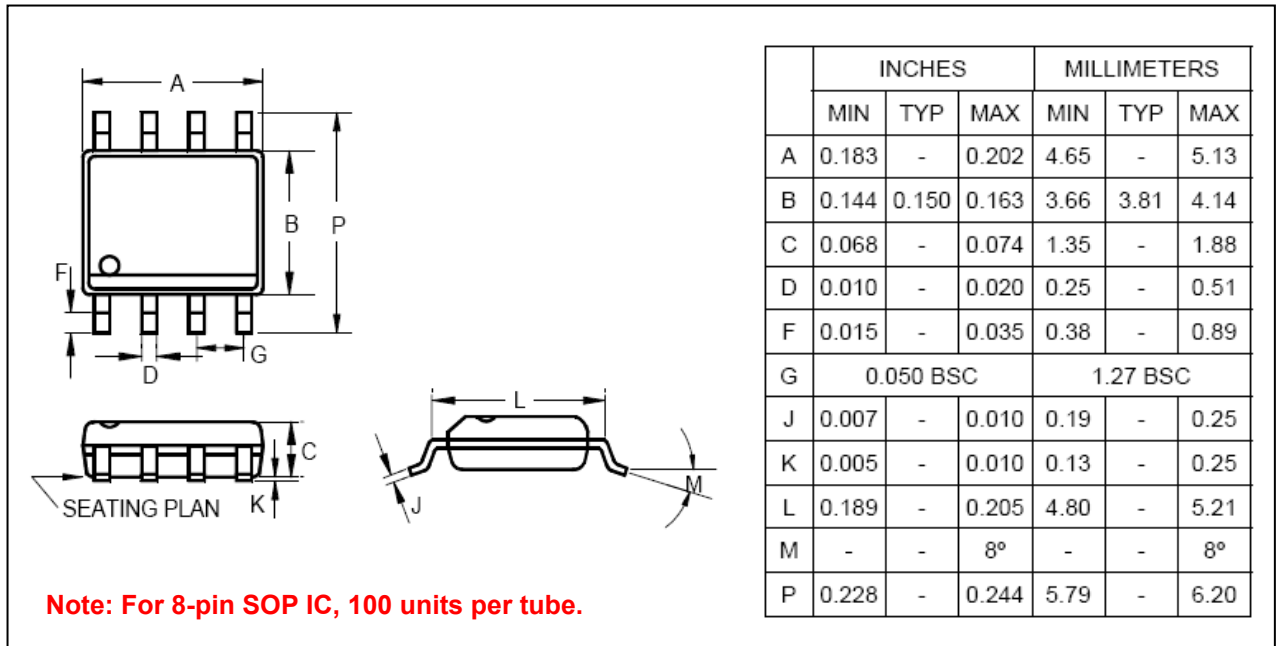

21.2 SOP-16 (150mil, 1.27mm pin pitch)

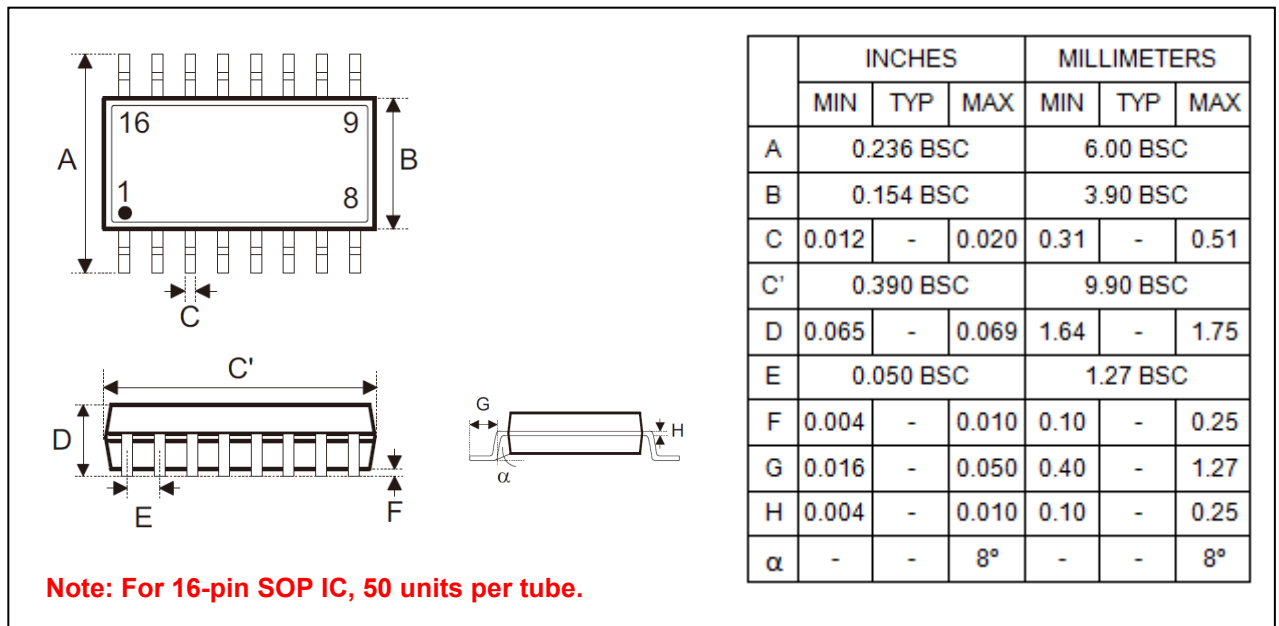

22. ORDERING INFORMATION

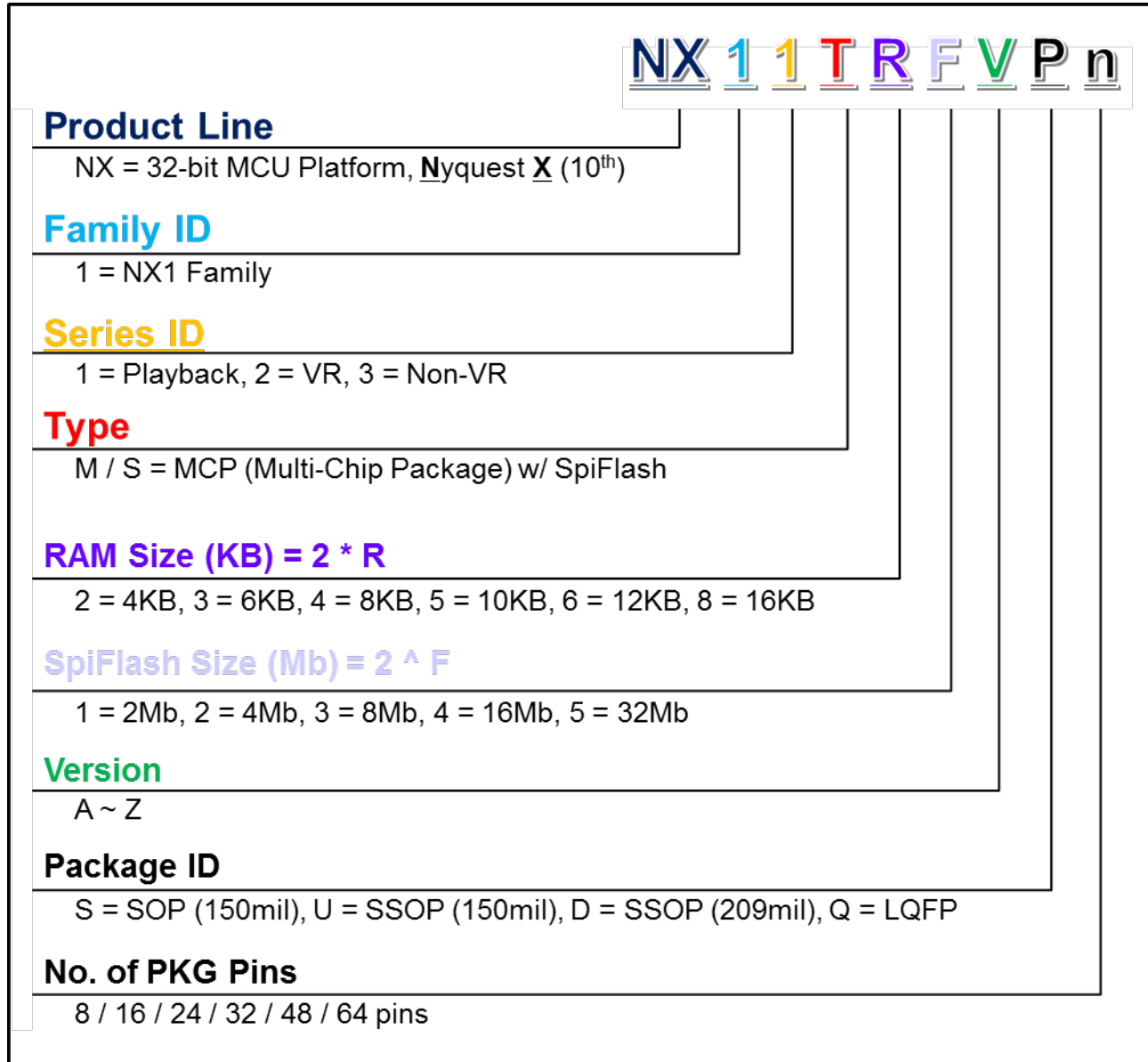

P/N	Shipping Type	Remark
NX11S21AS8	SOP-8 (MCP)	Width 150 mil, pitch 1.27mm
NX11S21AS16	SOP-16 (MCP)	Width 150 mil, pitch 1.27mm
NX11S22AS8	SOP-8 (MCP)	Width 150 mil, pitch 1.27mm
NX11S22AS16	SOP-16 (MCP)	Width 150 mil, pitch 1.27mm