



九齊科技股份有限公司
Nyquest Technology Co., Ltd.

DATA SHEET

NY3PxxxC Series (OTP for NY3)

5 I/O Single-Chip Speech Synthesizer

Version 1.0

May 23, 2023

NYQUEST TECHNOLOGY CO. reserves the right to change this document without prior notice. Information provided by NYQUEST is believed to be accurate and reliable. However, NYQUEST makes no warranty for any errors which may appear in this document. Contact NYQUEST to obtain the latest version of device specifications before placing your orders. No responsibility is assumed by NYQUEST for any infringement of patent or other rights of third parties which may result from its use. In addition, NYQUEST products are not authorized for use as critical components in life support devices/systems or aviation devices/systems, where a malfunction or failure of the product may reasonably be expected to result in significant injury to the user, without the express written approval of NYQUEST.

Revision History

<i>Version</i>	<i>Date</i>	<i>Description</i>	<i>Modified Page</i>
1.0	2023/05/23	Formal release.	-

1. 概述

NY3PxxxC系列產品為單晶片CMOS語音合成 IC，是九齊科技為了支援 NY3A, NY3B, NY3C, NY3D 系列MaskROM 產品所專門開發的嵌入式EPROM架構的OTP IC (One Time Programmable)，共有5個母體分別為 NY3P016C、NY3P035C、NY3P065C、NY3P087C 和 NY3P115C。最多有5個I/O腳，利用精準的內阻震盪(+/- 0.5%)，故不需外加震盪電阻，只有一組PWM輸出，故無須再外加任何零件。語音合成方式與NY3A, NY3B, NY3C, NY3D 系列MaskROM產品相同，藉由OTP燒錄過程中更換Code資料，可自行將不同的語音資料寫入EPROM中。用戶可使用簡便的 *Q-Speech* 和 *Quick-IO* 工具軟體來快速地進行開發，然後使用*Q-Writer*軟體搭配OTP_Writer硬體來進行非常快速的OTP燒錄。

2. 功能

(1). 寬廣的工作電壓：1.7V ~ 5.5V。

(2). 共有5個母體，對應不同NY3系列的容量(Hex-16進制)和秒數(@6kHz)如下：

	NY3P016C	NY3P035C	NY3P065C	NY3P087C	NY3P115C
NY3A	-	-	-	-	-
	-	-	-	-	-
NY3B	1DF00H	-	-	-	-
	20.44s	-	-	-	-
NY3C	1DF00H	3DF00H	7DF00H	A1F00H	DDF00H
	20.44s	42.28s	85.97s	110.55s	151.51s
NY3D	17F33H	318CCH	64C00H	818CCH	B18CCH
	16.35s	33.83s	68.78s	88.44s	121.21s

NY3A, NY3B, NY3C, NY3D 系列MaskROM產品的實際容量(Hex-16進制)和秒數(@6kHz)如下：

NY3A003E	NY3A006E	NY3A009E	NY3A012E
4800H	9000H	D800H	12000H
3.07s	6.14s	9.22s	12.29s

NY3B003C	NY3B007C	NY3B010C	NY3B014C	NY3B017C	NY3B021C
5400H	A800H	FC00H	15000H	1A400H	1F800H
3.58s	7.17s	10.75s	14.34s	17.92s	21.50s

NY3C003B	NY3C005B	NY3C007B	NY3C010B	NY3C016B	NY3C021C	NY3C027B	NY3C035C	NY3C043B	NY3C054C	NY3C065B
5C00H	7C00H	BB00H	FC00H	17C00H	1FC00H	27C00H	37C00H	3FC00H	4FC00H	5FC00H
3.93s	5.29s	7.98s	10.75s	16.21s	21.67s	27.14s	38.06	43.52	54.44	65.37

NY3D005B	NY3D010B	NY3D016B	NY3D021B	NY3D032C	NY3D043B	NY3D054B	NY3D065B	NY3D076B	NY3D087B	NY3D100B	NY3D115B
6C80H	EC80H	16C80H	1EC80H	2EC80H	3EC80H	4EC80H	5EC80H	6EC80H	7EC80H	96C80H	A6C80H
4.63s	10.09s	15.55s	21.01s	31.94s	42.89s	53.78s	64.70s	75.63s	86.55s	102.93s	113.86s

※ 注意: 使用NY3P(C) OTP模擬 MaskROM IC 時，可以在*Q-Speech*上將 *Voice Sections* 中的Factor參數調整到一樣，這樣 *Voice Data Size* 相同，音質才會一樣。

(3). 有5個I/O腳: OKY1/O5、OKY2/O4、IO1、IO2 和 IO3 可分別選作輸入腳或是輸出腳。

- (4). 語音最多可被分割成768個語音段(Voice Section)，每段長度可不同。每一個語音段的最大長度和最小長度都沒有限制。
- (5). 最多有1536個語音格(Voice Step)，可規劃成128個語音組(Voice Sentence)，OKY1/O5、OKY2/O4、IO1、IO2、IO3和POP能分別指定 64、60、1、1、1、1 個語音組(Sentence)。每一語音格(Step)可指定任一個語音段(Section)和 IO1、IO2、IO3、OKY2/O4、OKY1/O5 的輸出搭配(當IOx設為輸出時)。
- (6). 只有內建一組準確的頻率振盪器(+/- 0.5% 誤差)，並無提供外部震盪電阻選項。可分別支援NY3A, NY3B, NY3C, NY3D 系列不同的播放速度選項。

(a) NY3A 和 NY3B 的27種播放速度選項：

1	2	3	4	5	6	7	8	9	10
20.0kHz	17.1kHz	15.0kHz	13.3kHz	12.0kHz	10.9kHz	10.0kHz	9.2kHz	8.6kHz	8.0kHz
11	12	13	14	15	16	17	18	19	20
7.5kHz	7.1kHz	6.7kHz	6.3kHz	6.0kHz	5.7kHz	5.5kHz	5.2kHz	5.0kHz	4.8kHz
21	22	23	24	25	26	27			
4.6kHz	4.4kHz	4.3kHz	4.1kHz	4.0kHz	3.9kHz	3.8kHz			

(b) NY3C 和 NY3D 的28種播放速度選項：

1	2	3	4	5	6	7	8	9	10
24.0kHz	20.0kHz	17.1kHz	15.0kHz	13.3kHz	12.0kHz	10.9kHz	10.0kHz	9.2kHz	8.6kHz
11	12	13	14	15	16	17	18	19	20
8.0kHz	7.5kHz	7.1kHz	6.7kHz	6.3kHz	6.0kHz	5.7kHz	5.5kHz	5.2kHz	5.0kHz
21	22	23	24	25	26	27	28		
4.8kHz	4.6kHz	4.4kHz	4.3kHz	4.1kHz	4.0kHz	3.9kHz	3.8kHz		

(7). I/O 對應圖：

NY3P(C)	OKY1/O5	OKY2/O4	IO1	IO2	IO3
NY3A	OKY	-	-	-	-
NY3B	OKY	-	IO1	-	-
NY3C	OKY/O3	-	IO1	IO2	-
NY3D	OKY1/O5	OKY2/O4	IO1	IO2	IO3

(8). 輸入腳的輸入選項：

- (a). 任一輸入腳可分別選擇 Edge/Level, Hold/Unhold, Retrigger/Irretrigger 不同的觸發方式組合。
- (b). 任一輸入腳可分別選擇 CDS+1.5M、CDS、1.5M 的下拉電阻 或 Floating。(CDS+1.5M選項: 當按鍵按下時，IC內部為 1.5M 的下拉電阻；而當按鍵放開時，IC內部為 300K+1.5M 並聯 的下拉電阻 約250K。CDS: 當按鍵按下時，IC內部為 Floating；而當按鍵放開時，IC內部為 300K 的下拉電阻。)
- (c). 任一輸入腳可分別選擇Debounce時間：Long - 提供一般按鍵使用；Short - 提供彈跳開關使用。
- (d). OKY1/O5和OKY2/O4輸入腳最多各有64和60個Sentence的One-Key sequential 或 random 的選擇，在 One-Key sequential 時並可選擇Sentence的播放順序在其他按鍵被觸發後是否要Reset。
- (e). 只有一個輸入腳可選擇是否有 Toggle On/Off 的功能 (1st 觸發 → 播放，2nd 觸發 → 停止，……)。

※ 注意: 按鍵輸入的優先順序為 OKY1/O5 > OKY2/O4 > IO1 > IO2 > IO3。

- (9). 所有的輸出腳都有以下 4 種輸出電流選項：
- (a). Normal Sink Current Output (一般灌電流輸出)：輸出腳接LED到VDD。 $(I_{ol}=22mA/33mA @V_{DD}=3V/4.5V)$
 - (b). Large Sink Current Output (大灌電流輸出)：輸出腳接LED到VDD。 $(I_{ol}=60mA/85mA @V_{DD}=3V/4.5V)$
 - (c). Constant Sink Current Output (定灌電流輸出)：輸出腳接LED到VDD，VDD=3V和4.5V的輸出電流為恆定電流，不會因為VDD不同而影響到LED亮度。 $(I_{ol}=20mA/21mA @V_{DD}=3V/4.5V)$
 - (d). Drive Current Output (拉電流輸出)：輸出腳接LED到GND。 $(I_{oh}=7mA/11mA @V_{DD}=3V/4.5V)$
- (10). 所有的輸出腳都分別有以下 9 種輸出選項：
- (a). Stop_Low pulse：停止播放時送出低位準脈衝。
 - (b). Stop_High pulse：停止播放時送出高位準脈衝。*(注意: OKY1/O5 不支援此選項)*
 - (c). Busy_High active：播放時送出高位準訊號。(Drive輸出) *(注意: OKY1/O5 不支援此選項)*
 - (d). Busy_Low active：播放時送出低位準訊號。(Sink輸出)
 - (e). LED 1.5Hz flash：播放時 LED 1.5Hz Sink輸出閃爍。
 - (f). LED 3Hz flash：播放時 LED 3Hz Sink輸出閃爍。
 - (g). LED 6Hz flash：播放時 LED 6Hz Sink輸出閃爍。
 - (h). LED dynamic 1/2：播放時 LED根據1/2聲音位準做Sink輸出動態閃爍。
 - (i). QIO訊號：可隨聲音作任意的輸出變化，IO1、IO2、IO3各有兩組QIO訊號，每一個語音格(Step)可選擇兩組QIO訊號的其中一組，但OKY2/O4只有一組QIO訊號可供選擇，而OKY1/O5並沒有提供QIO選項。用戶使用此功能需先開啟Quick-IO編輯器來做QIO訊號編輯。
- ※ 注意: LED 1.5Hz / 3Hz / 6Hz flash 是指以 6kHz 的播放速度 時LED閃爍的頻率；不同的播放速度，LED閃爍的頻率也會不同。*
- (11). 特殊功能選項 "模式切換" (Mode-Switch)：有兩種功能模式，可使用IO1或IO3輸入來當作模式切換開關 (Mode-Switch)，模式一(IO1→GND) 與 模式二(IO1→VDD) 的所有輸出型態(Output Type)只能相同，但是I/O功能和語音內容可以不同。
- (12). 特殊功能選項 "上電播放" (Power-On-Play, POP)：電池一上電立即播放一次"上電播放語音組"(POP Sentence)，觸發模式固定為 Edge / Unhold / Retrigger。如果POP結合 Power-On-Loop (POL) 功能，則上電會循環播放"上電播放語音組"(POP Sentence)。如果POP結合 Power-On-Loop Interrupt (POP Interrupt) 功能，則上電播放時有其他按鍵被觸發，上電播放會立即停止並播放該按鍵所指定的語音組。如果POP結合Mode-Switch功能，則當模式切換後會先執行上電播放。
- (13). 特殊功能選項 "特殊聲控" (Special SC)：當聲控輸入與按鍵輸入同時存在，可以讓聲控輸入不會產生誤觸發，此時聲控輸入腳只能連接到OKY2/O4或IO3。當透過聲控觸發OKY2/O4或IO3來播放語音時，按下其他按鍵可以中斷語音播放，但當IC接受任何的觸發而播放語音時，聲控並無法被觸發。此功能可以讓使用者在同一個模組同時具備聲控和按鍵並存的功能，讓聲控不會干擾到按鍵的正常操作。
- (14). 特殊功能選項 "馬達復位" (Motor-Recover)：當使用復位馬達時可選擇此功能，使用者可以選擇OKY2/O4或IO3當作馬達復位偵測腳，來判斷馬達是否已經回到初始位置。此時IO2將會被預設為馬達復位輸出腳位，有3種不同的馬達復位訊號的選項：DC(直推訊號)、6Hz(6Hz頻率訊號)和12Hz(12Hz頻率訊號)。

- (15). 特殊功能選項 ”按鍵優先順序” (2-Key Priority)：使用者可以決定先後按下兩鍵的優先播放順序，有2種順序選項：First Key (前鍵優先) 和 Last Key (後鍵優先)。First Key為先按的按鍵優先，為一般正常的操作；Last Key則為後按的按鍵優先，然而Last Key只支援OKY1/O5及OKY2/O4，使用者可以根據應用需求來使用Last Key。
- (16). 特殊功能選項 ”觸發反向” (TG-Invert)：當語音格選取Invert功能時，在播放該段聲音時，原本輸入觸發的Retrigger/Irretrigger模式會反轉。使用者可以根據應用需求在適當的語音格插入Invert功能，以改變觸發模式。
- (17). 特殊功能選項 ”隨機列表播放” (Table Random)：當使用者需要可以平均的隨機播放好幾個語音組時可以選擇此功能。第一次觸發OKY1，會隨機選擇 OKY1 Sentences Table 內的其中一個語音組來播放，之後的OKY1觸發，則在第一次觸發的語音組之後循序播放。
- (18). 特殊功能選項 ”暫停/恢復播放” (Pause-Resume)：在播放OKY1的語音組時，當OKY1按鍵一被觸發，則語音組會暫停播放，此時LED全滅，IC會進入睡眠狀態(Sleep Mode)，靜態電流非常小(0.05uA)，再次觸發OKY1則會從之前語音組暫停的地方恢復播放。
- ※ 注意: Pause-Resume 不能和 Toggle On/Off 功能同時存在。*
- (19). 特殊功能選項 ”內部觸發” (Internal-Feedback)：此功能有兩組。當OKY1(OKY2) 的聲音播放中被重覆觸發或聲音播放結束時，利用內部的Stop_High-Pulse信號來自動觸發 OKY2(OKY1) 所指定的語音組(Internal-Feedback Path)，播放該語音組一次。
- ※ 注意: 當啟動此功能時，OKY1 或 OKY2 只能當做輸入腳。*
- (20). 特殊功能選項 ”防干擾Debounce” (Anti-Noise Debounce)：設定輸入腳的訊號觸發需要先偵測到一段低電平(Low)的Debounce時間，才會進行正常的高電平(High)觸發的Debounce偵測。此功能可以用來避免外部的馬達雜訊干擾，並不會因為按鍵過程中的觸發訊號被雜訊拉低，導致IC重複觸發。
- ※ 注意: 當啟動此功能時，所有輸入口都會被設定為 Anti-Noise Debounce 功能。*
- (21). 序列觸發功能(Serial-Trigger): 在 Edge/Unhold/Retrigger 觸發模式下，使用OKY1或OKY2的 One-Key Sequential 和 Reset 功能，並設定觸發Debounce時間為Short Debounce，這樣就可以利用外部序列訊號輸入來控制OKYx 的特定Sentence播放，通常搭配外部MCU來控制。
- (22). 一組 9-bit 或 10-bit 的PWM輸出可支援 NY3A/NY3B/NY3C 的 9-bit 或 NY3D 的 10-bit PWM 輸出，有兩種 PWM音量可供選擇 (正常音量&大音量)，可直接驅動8Ω、16Ω、32Ω、64Ω的喇叭或蜂鳴片。
- (23). 支援低壓復位(LVR=1.5V)功能。
- (24). 提供特殊的快速燒錄模式，以加快OTP燒錄時間。
- (25). 支援特殊的ICP (In Circuit Programming) 燒錄功能，以方便客戶先組裝PCBA模組再進行燒錄。
- (26). 提供可程式的Code資料保護模式。*(當Security-Bit 被燒斷後，資料將無法讀取。)*
- (27). 提供多種出貨型態，以滿足客戶不同的應用需求。

(要進一步了解上述功能，請參考NY3A, NY3B, NY3C 和 NY3D 的規格書。)

1. GENERAL DESCRIPTION

The NY3PxxxC series are single-chip voice synthesizing CMOS IC. They are embedded EPROM architecture, and OTP (One Time Programmable) IC that are designed to support NY3A, NY3B, NY3C and NY3D MaskROM products. There are 5 bodies: NY3P016C, NY3P035C, NY3P065C, NY3P087C and NY3P115C. There are maximum five I/O pins. Through accurate internal oscillation of +/- 0.5% tolerance, an external R_{osc} is unnecessary. There is only one PWM output for voice. Thus any external component is not required. Using the same speech algorithm as NY3A, NY3B, NY3C and NY3D, customer's speech data can be written into EPROM by different code data. Besides, two interactive software developing tools of "Q-Speech" & "Quick-IO" are user-friendly and quick for programming, then users can write BIN code into OTP very fast by "Q-Writer" software cooperating with "OTP_Writer" hardware.

2. FEATURES

(1). Wide operating voltage: 1.7V ~ 5.5V.

(2). There are 5 bodies. Corresponding to different NY3 series, the supported ROM size in Hex and speech duration at 6kHz are as following.

	NY3P016C	NY3P035C	NY3P065C	NY3P087C	NY3P115C
NY3A	-	-	-	-	-
	-	-	-	-	-
NY3B	1DF00H	-	-	-	-
	20.44s	-	-	-	-
NY3C	1DF00H	3DF00H	7DF00H	A1F00H	DDF00H
	20.44s	42.28s	85.97s	110.55s	151.51s
NY3D	17F33H	318CCH	64C00H	818CCH	B18CCH
	16.35s	33.83s	68.78s	88.44s	121.21s

For NY3A, NY3B, NY3C and NY3D MaskROM product series, the actual ROM size in Hex and speech duration at 6kHz are as following.

NY3A003E	NY3A006E	NY3A009E	NY3A012E
4800H	9000H	D800H	12000H
3.07s	6.14s	9.22s	12.29s

NY3B003C	NY3B007C	NY3B010C	NY3B014C	NY3B017C	NY3B021C
5400H	A800H	FC00H	15000H	1A400H	1F800H
3.58s	7.17s	10.75s	14.34s	17.92s	21.50s

NY3C003B	NY3C005B	NY3C007B	NY3C010B	NY3C016B	NY3C021C	NY3C027B	NY3C035C	NY3C043B	NY3C054C	NY3C065B
5C00H	7C00H	BB00H	FC00H	17C00H	1FC00H	27C00H	37C00H	3FC00H	4FC00H	5FC00H
3.93s	5.29s	7.98s	10.75s	16.21s	21.67s	27.14s	38.06	43.52	54.44	65.37

NY3D005B	NY3D010B	NY3D016B	NY3D021B	NY3D032C	NY3D043B	NY3D054B	NY3D065B	NY3D076B	NY3D087B	NY3D100B	NY3D115B
6C80H	EC80H	16C80H	1EC80H	2EC80H	3EC80H	4EC80H	5EC80H	6EC80H	7EC80H	96C80H	A6C80H
4.63s	10.09s	15.55s	21.01s	31.94s	42.89s	53.78s	64.70s	75.63s	86.55s	102.93s	113.86s

※ Note: Using NY3P(C) OTP to simulate NY3 MaskROM IC, users may adjust the Factor parameter of Voice Sections in Q-Speech to get same Voice Data Size for same sound quality.

- (3). Five I/O pins: OKY1/O5, OKY2/O4, IO1, IO2 and IO3 can be either input or output pin.
- (4). The total voice duration can be partitioned up to maximum 768 Voice Sections. Each Voice Section length is flexible and each maximum or minimum Voice Section length is unlimited.
- (5). Total maximum 1536 Voice Steps are available for 128 Voice Sentences. OKY1/O5, OKY2/O4, IO1, IO2, IO3 and POP can assign 64, 60, 1, 1, 1 and 1 Sentences independently. Each Step can specify one Voice Section and enable/disable IO1, IO2, IO3, OKY2/O4, OKY1/O5 output option if IOx is set as output.
- (6). Only build in an accurate internal oscillator of +/- 0.5% tolerance, no external R oscillator. It can support different play speed option of NY3A, NY3B, NY3C and NY3D individually.

(a) NY3A & NY3B: 27 kinds of play speed option.

1	2	3	4	5	6	7	8	9	10
20.0kHz	17.1kHz	15.0kHz	13.3kHz	12.0kHz	10.9kHz	10.0kHz	9.2kHz	8.6kHz	8.0kHz
11	12	13	14	15	16	17	18	19	20
7.5kHz	7.1kHz	6.7kHz	6.3kHz	6.0kHz	5.7kHz	5.5kHz	5.2kHz	5.0kHz	4.8kHz
21	22	23	24	25	26	27			
4.6kHz	4.4kHz	4.3kHz	4.1kHz	4.0kHz	3.9kHz	3.8kHz			

(b) NY3C & NY3D: 28 kinds of play speed option.

1	2	3	4	5	6	7	8	9	10
24.0kHz	20.0kHz	17.1kHz	15.0kHz	13.3kHz	12.0kHz	10.9kHz	10.0kHz	9.2kHz	8.6kHz
11	12	13	14	15	16	17	18	19	20
8.0kHz	7.5kHz	7.1kHz	6.7kHz	6.3kHz	6.0kHz	5.7kHz	5.5kHz	5.2kHz	5.0kHz
21	22	23	24	25	26	27	28		
4.8kHz	4.6kHz	4.4kHz	4.3kHz	4.1kHz	4.0kHz	3.9kHz	3.8kHz		

(7). I/O mapping table.

NY3P(C)	OKY1/O5	OKY2/O4	IO1	IO2	IO3
NY3A	OKY	-	-	-	-
NY3B	OKY	-	IO1	-	-
NY3C	OKY/O3	-	IO1	IO2	-
NY3D	OKY1/O5	OKY2/O4	IO1	IO2	IO3

(8). Input option for input pin:

- (a). Each input can select Edge/Level, Hold/Unhold and Retrigger/Irretrigger trigger modes.
- (b). Each input can select CDS+1.5M, CDS, 1.5M pull-low resistor or Floating type.
(CDS+1.5M option: Only 1.5M pull-low resistance at key-pressed, and 300K+1.5M in parallel pull-low resistance around 250K at key-released. CDS option: Floating at key-pressed, and 300K pull-low resistance at key-released.)
- (c). Each input can select Debounce time: Long debounce for push-button. Short debounce for fast switch.
- (d). OKY1/O5 & OKY2/O4 input can select One-Key Sequential or Random for maximum 64 & 60

Sentences independently. At One-Key Sequential, the Reset function of playing *Sentence* sequence can be selected or not when other keys are triggered.

(e). Only one input pin can select Toggle On/Off function (1st Trigger → play, 2nd trigger → stop,).

※ Note: Input priority is OKY1/O5 > OKY2/O4 > IO1 > IO2 > IO3.

(9). There are 4 kinds of output current option for all output pins.

(a). Normal Sink Current output: Output is connected a LED with VDD. ($I_{ol}=22\text{mA}/33\text{mA}$ @ $V_{DD}=3\text{V}/4.5\text{V}$)

(b). Large Sink Current output: Output is connected a LED with VDD. ($I_{ol}=60\text{mA}/85\text{mA}$ @ $V_{DD}=3\text{V}/4.5\text{V}$)

(c). Constant Sink Current output: Output is connected a LED with VDD. Whenever VDD is 3V or 4.5V, the output current is constant and LED brightness is uniform. ($I_{ol}=20\text{mA}/21\text{mA}$ @ $V_{DD}=3\text{V}/4.5\text{V}$)

(d). Drive Current output: Output is connected a LED with GND. ($I_{oh}=7\text{mA}/11\text{mA}$ @ $V_{DD}=3\text{V}/4.5\text{V}$)

(10). There are 9 kinds of output option for all output pins:

(a). Stop_Low pulse: Low active stop-pulse output whenever device stops playing.

(b). Stop_High pulse: high active stop-pulse output whenever device stops playing.

(※ Note: This option is not available for OKY1/O5.)

(c). Busy_High active: high active signal output during playing. (Drive output)

(※ Note: This option is not available for OKY1/O5.)

(d). Busy_Low active: low active signal output during playing. (Sink output)

(e). LED 3Hz flash: 3Hz sink signal output to drive LED during playing.

(f). LED 6Hz flash: 6Hz sink signal output to drive LED during playing.

(g). LED 12Hz flash: 12Hz sink signal output to drive LED during playing.

(h). LED dynamic 1/2: according to 1/2 sound level, dynamic sink signal output to drive LED during playing.

(i). QIO signal: arbitrary output with voice. For IO1, IO2 and IO3, there are two sets of QIO signal. Each *Voice Step* can select one set of QIO signal. But for OKY2/O4, there is only one set of QIO signal to select. **And for OKY1/O5, there is no QIO signal to select.** User can edit the QIO signal by “Quick-IO” editor.

※ Note: Where (e) ~ (g) is the LED flash rate at 6kHz sample rate. For different play speed, the LED flash rate is different from original 1.4Hz, 3Hz or 6Hz.

(11). “*Mode-Switch*” special function: There is two kinds of functional modes that can be switched by IO1 or IO3 input (Mode-Switch). For Mode-1 (IO1 → GND) and Mode-2 (IO1→VDD), the output type of I/O setting is the same, but I/O function and voice/melody can be different.

(12). “*Power-On-Play*” special function (POP): When power is on, play the POP *Sentence* one time. The trigger mode is fixed as Edge / Unhold / Retrigger. To cooperate with Power-On-Loop function, the POP *Sentence* will be played in loop until other key-trigger happened. When other key is triggered, it stops playing the POP *Sentence* and immediately plays the assigned sentence of triggered key.

(13). “*Special SC*” special function: When sound-control input stands with push-button input together, sound-control won’t mis-trigger IC. The sound-control input pin can only be connected to OKY2/O4 or IO3. While playing voice by sound-control input, to press push-button input can stop voice paying. But while playing

voice by push-button input, sound-control input can't trigger IC to stop voice playing. This special function can be applied in one module with both sound-control input and push-button input, i.e. sound-control won't affect normal operation of push-button key trigger.

- (14). “*Motor-Recover*” special function: User can select this function when using the recovering motor. In this application, IO2 is set as output to control the recovering motor. And the motor recovering sensor must be connected to OKY2/O4 or IO3 to detect the recovering signal.
- (15). “*2-Key Priority*” special function: Users can decide the priority of 2 different keys when both keys are pressed at the same time. There are two kinds of priority option: First Key and Last Key. For First Key, the prior pressed key is first priority to play voice, and it's normal operation. As for Last Key, the later pressed key is first priority to play voice, and it only supports OKY1/O5 and OKY2/O4 input pins. Users can use Last Key option according to application requirement.
- (16). “*TG-Invert*” special function: When one *Voice Step* is optioned with Invert function, the trigger mode of Retrigger/Irretrigger will be inverted during playing that *Voice Section*. Users can insert Invert function in specific steps according to application requirement to change the trigger mode.
- (17). “*Table Random*” special function: When users need to play several sentences randomly and averagely, this function can be applied. At first trigger of OKY1, one random sentence will be played from OKY1 Sentences Table. After that, the played sentences for following OKY1 triggers will be sequential.
- (18). “*Pause-Resume*” special function: At playing OKY1 sentence, when key is triggered, the sentence playing will be paused, all LEDs are turned off and IC will enter sleep mode. At this moment, the standby current is very small about 0.05uA. To trigger OKY1 again, the sentence will resume and play sentence from the pause point.
※ Note: Pause-Resume function cannot co-exist with Toggle On/Off function.
- (19). “*Internal-Feedback*” special function: There are 2 sets of this function. When the playing sentence of OKY1(OKY2) is stopped or over, continue to play the assigned sentence of OKY2(OKY1) through internal Stop_High-Pulse signal (Internal-Feedback Path).
※ Note: When enable this function, OKY1/O5 or OKY2/O4 is fixed as input pin.
- (20). “*Anti-Noise Debounce*” special function: For a right trigger detection, the trigger signal needs a low-level Debounce time in advance of normal Debounce detection for high-level signal. It is used to prevent noise interference such like motor noise. With this function, the trigger signal won't result in double-trigger which usually occur when noise pull the high signal to low.
※ Note: When enable this function, all inputs are optioned as Anti-Noise Debounce function.
- (21). Serial-Trigger function: In Edge/Unhold/Retrigger mode, by using the One-Key Sequential and Reset functions of OKY1 or OKY2 and setting the Debounce time to be short, IC can access external serial clock signal to playback the specific Sentence of OKYx. Usually it cooperates with an external MCU.
- (22). One 9-bit or 10-bit PWM output for NY3A/NY3B/NY3C 9-bit or NY3D 10-bit PWM output. There are 2 kinds of PWM output, normal and large. It can directly drive 8, 16, 32, 64Ω speaker or piezo-buzzer.

- (23). Low Voltage Reset (LVR=1.5V) is supported.
- (24). A unique fast writing mode is provided to speed up OTP writing time.
- (25). A special *ICP* (In Circuit Programming) writing function is supported for user to fabricate PCBA in advance.
- (26). Programmable code protection is provided. *(When the Security-Bit is burnt down, data can't be read.)*
- (27). Various shipping type for different application requirement.

(For details of the above functions, please refer to NY3A, NY3B, NY3C and NY3D datasheet.)

3. BLOCK DIAGRAM

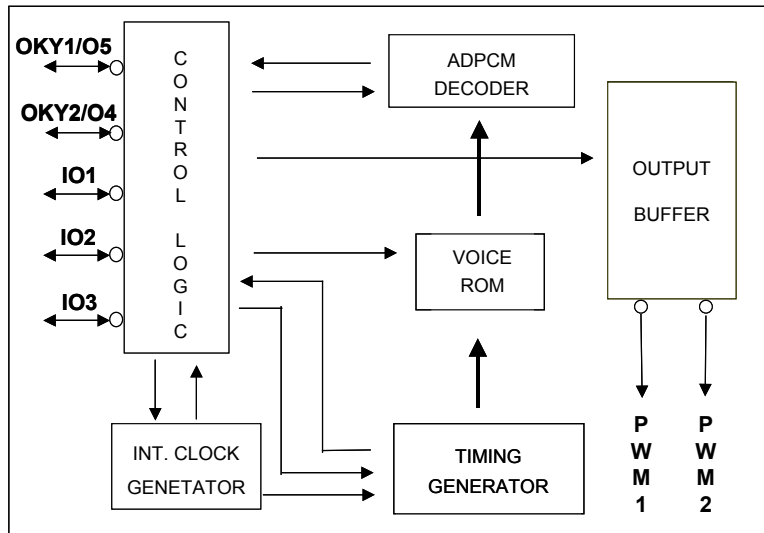

4. PAD DESCRIPTION

Pad Name	Pad No.	ATTR.	Description
OKY1/O5 /Vpp	1	I	Input pin, active high, or positive high power for programming.
OKY2/O4	2	I/O	Output or input pin. To be input, active high.
IO1 /SDA	3	I/O	Output or input pin. To be input, active high.
IO2 /SCL	4	I/O	Output or input pin. To be input, active high.
IO3	5	I/O	Output or input pin. To be input, active high.
GND	6	Power	Negative power.
VDD	7	Power	Positive power.
PWM1	8	O	PWM output 1.
PWM2 /Mode	9	O	PWM output 2, or select programming mode.

5. DEVELOPMENT, DEMONSTRATION & PRODUCTION

User can use “Q-Speech” & “Quick-IO” software to develop the desired functions. After finishing the code programming, user will get 2 files of “.bin” and “.htm”, the binary file and function check list. Through “OTP_Writer” operation, user can download the “.bin” file into NY3P(C) chips to demonstrate the NY3 function. Customer can make pilot production by NY3P(C) OTP directly, or can send the “.bin” file to Nyquest to release MaskROM code for mass production. For more details, please refer to “Q-Speech” & “Quick-IO” user manual.

6. ABSOLUTE MAXIMUM RATING

Symbol	Rating	Unit
VDD~GND	-0.5 ~ +6.0	V
V _{in}	GND-0.3 < V _{in} < VDD+0.3	V
V _{out}	GND < V _{out} < VDD	V
T _{op} (operating)	-0 ~ +70	°C
T _{st} (storage)	-55 ~ +150	°C

7. DC CHARACTERISTICS

Symbol	Parameter	VDD	Min.	Typ.	Max.	Unit	Condition
VDD	Operating voltage	--	1.7	3.0	5.5	V	1.54MHz
I _{SB}	Standby current	3.0		1.2		uA	LVR and POP disabled
		4.5		1.5			
		3.0		2.0		uA	LVR or POP enabled
		4.5		3.0			
I _{OP}	Operating current	3.0		0.5		mA	No load.
		4.5		0.7			
I _{IH}	Input current (1.5M ohms pull-low)	3.0		2		uA	V _{IL} =VDD
		4.5		5			
	Input current (300K ohms pull-low)	3.0		30		uA	
		4.5		85			
I _{OH}	Output drive current	3.0		-7		mA	V _{OH} =2.0V
		4.5		-11			V _{OH} =3.5V
I _{OL}	Output normal sink current	3.0		22		mA	V _{OL} =1.0V
		4.5		33			
	Output large sink current	3.0		60		mA	
		4.5		85			
	Output constant sink current	3.0		20		mA	
		4.5		21			
I _{PWM}	PWM output current (Normal)	3.0		60		mA	Load=8 ohms
		4.5		100			
	PWM output current (Large)	3.0		70		mA	
		4.5		117			
ΔF/F	Frequency deviation by voltage drop	3.0		-0.5		%	$\frac{F_{osc(3.0v)} - F_{osc(2.4v)}}{F_{osc(3v)}}$
		4.5		0.5			$\frac{F_{osc(4.5v)} - F_{osc(3.0v)}}{F_{osc(4.5v)}}$
	Frequency lot deviation	--		+0.5		%	$\frac{F_{max(VDD)} - F_{min(VDD)}}{F_{max(VDD)}}$
F _{osc}	Oscillation Frequency	--	1.52	1.54	1.56	MHz	VDD=1.7~5.5V

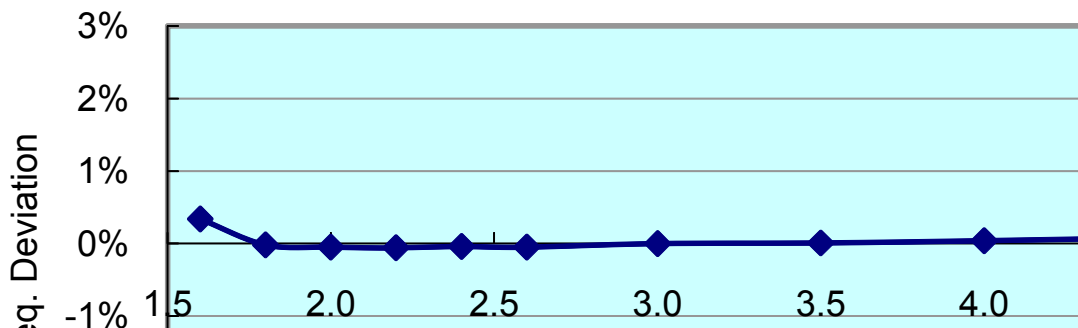
Voltage vs Freq. Deviation (SF)

8. TIMING DIAGRAM

(1) Debounce Time

(a). Trigger while no playing voice

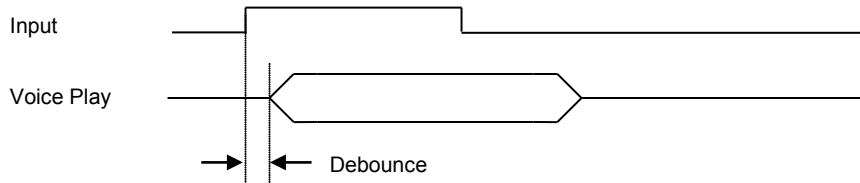

※ Debounce time is configured by 6.67 kHz S.R and the value is fixed. That is, Long debounce=31ms, Short debounce = 42us

(b). Trigger While playing voice

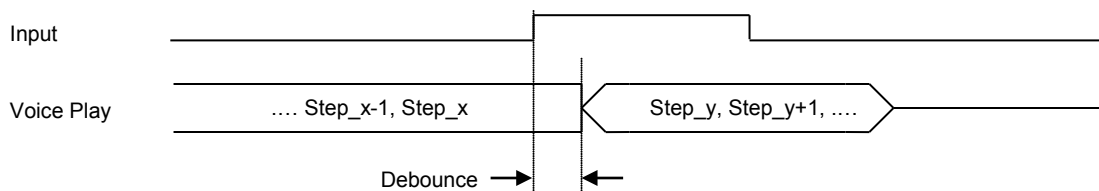

※ Debounce Time is configured by the S.R. of Step_x. At S.R. = 6kHz, Long debounce = 45ms, Short debounce = 50us

For example, if Step_x S.R. = 8kHz, Long debounce = 45ms*(6k/8k) = 15ms, Short debounce = 50us*(6k/8k) = 37.5us

(2) Input Priority



※ Priority: OKY1/O5 > OKY2 > IO1 > IO2 > IO3

(3) Output Signal (IO1, IO2, IO3, O4)

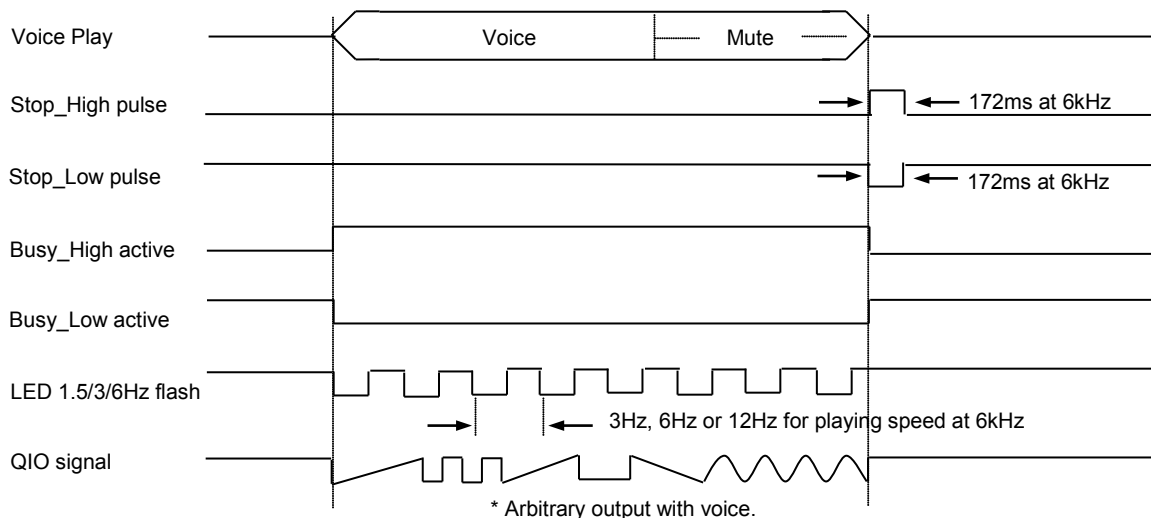

LED dynamic 1/2: When the voice amplitude is higher than 1/2 level, LED will be ON, i.e. output signal is low.

(4) Basic Operation

(a). Edge mode, Edge trigger

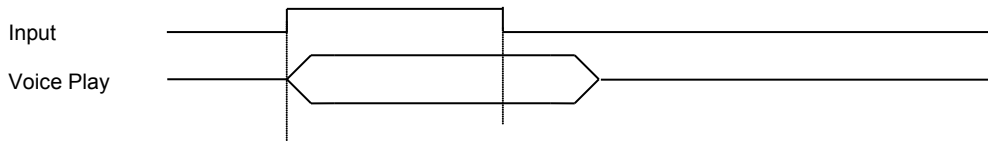

(b). Edge mode, Level trigger

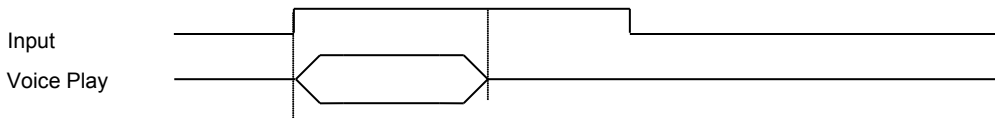

(c). Level mode, Edge trigger

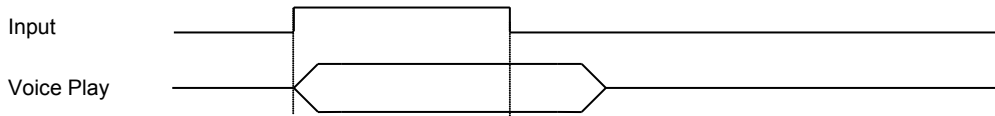

(d). Level mode, Level trigger

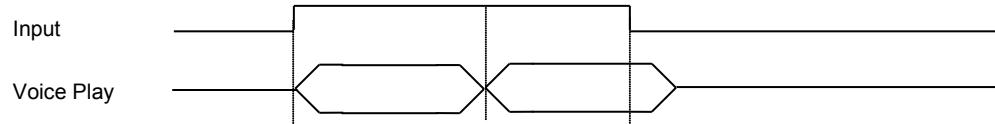

(e). Retrigger mode

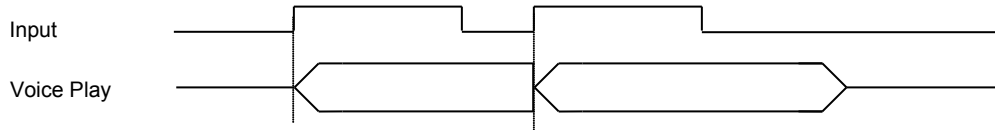

(f). Irretrigger mode

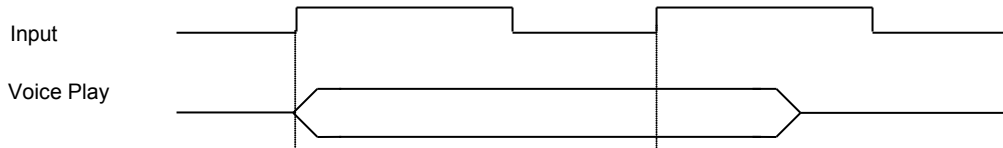

(g). Retrigger mode, first key priority

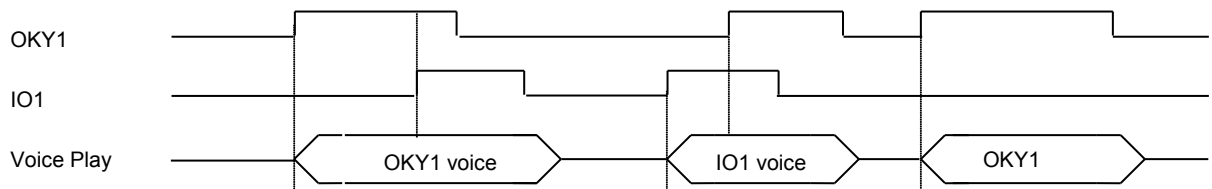

(5) Advanced Operation

(a). Different Input Reload (OKY1 is in Sequential mode)

(a-1) OKY1 (E/U/R) = S1 S2 S3 S4, IO1(E/U/R) = S5 (S1 means Sentence 1)

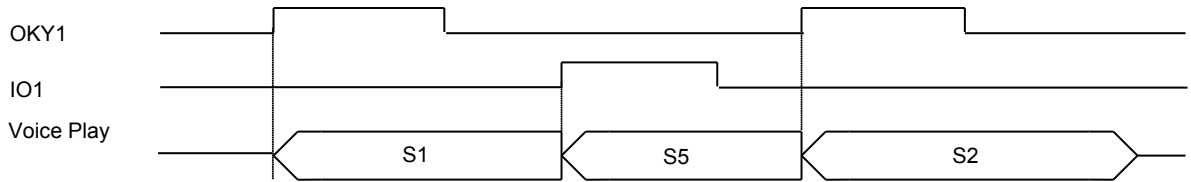

(a-2) OKY1 (E/U/R) = S1 S2 S3 S4, IO1 (L/x/x) = S5

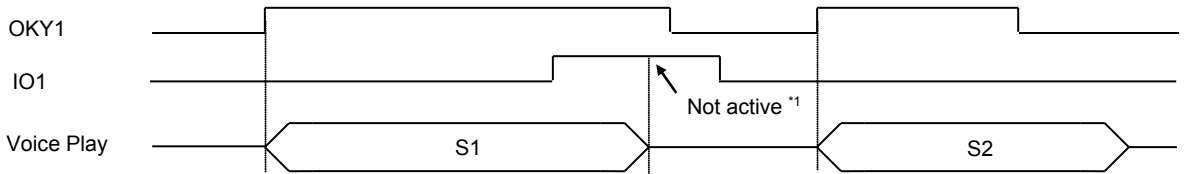

*1: If you press IO1 during OKY1 voice playing, at the moment of S1 end, the trigger mode follows OKY1

(a-3) OKY1 (E/U/I) = S1 S2 S3 S4, IO1 (E/x/x) = S5

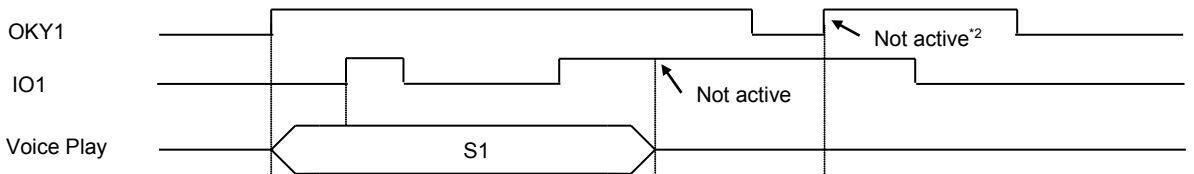
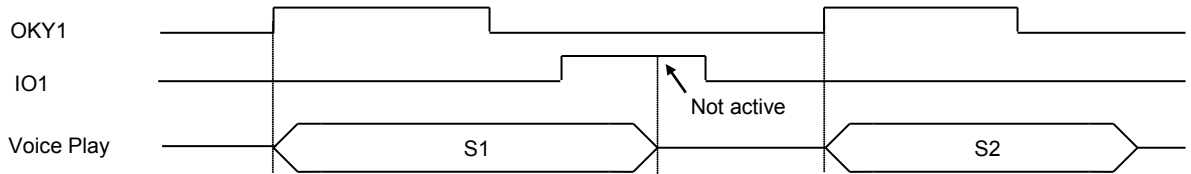

*2: Because IO1 signal is still high in the same time IC can't accept the OKY1 Edge signal.

(a-4) OKY1 (E/U/I) = S1 S2 S3 S4, IO1 (L/x/x) = S5

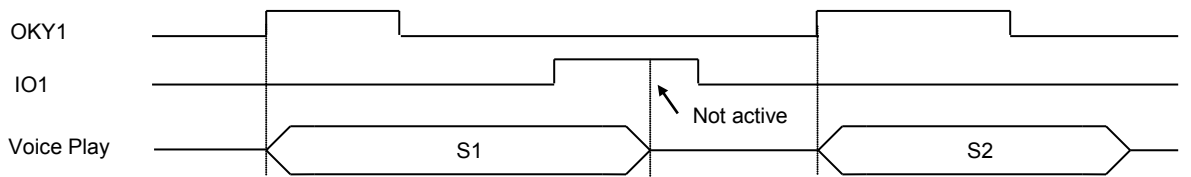

(a-5) OKY1 (L/U/x) = S1 S2 S3 S4, IO1 (E/x/x) = S5

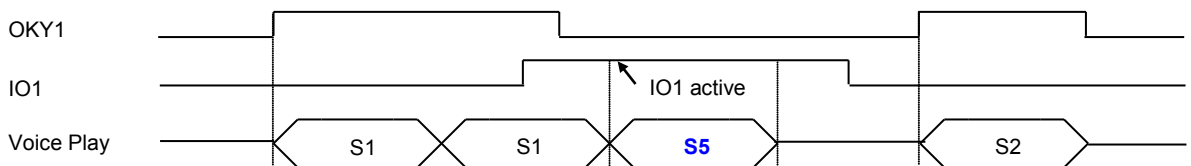

※ In the time of Sentence end: When S1 end, the trigger mode follows OKY1 (L/U/x). When S5 end, it follows IO1 (E/x/x).

※ Once S5 is played (just leave S1 ending), the trigger mode follows IO1 (E/x/x) immediately.

(a-6) OKY1 (L/U/x) = S1 S2 S3 S4, IO1 (L/U/I) =S5

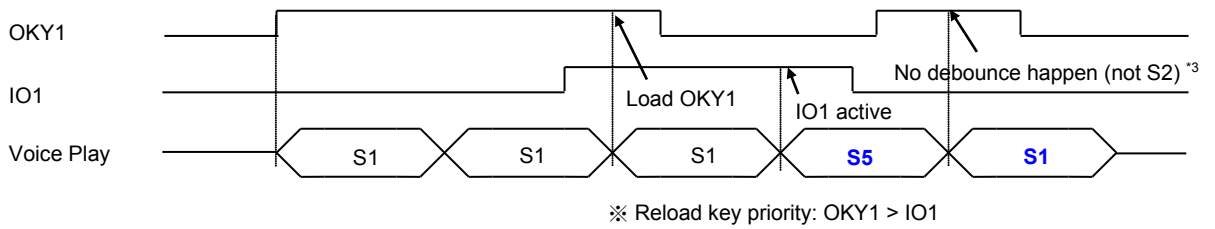

*3: In OKY1 mode, Sequential number is counted only if there is debounce happened.

(a-7) OKY1 (L/U/x) = S1 S2 S3 S4, IO1 (L/U/x) =S5

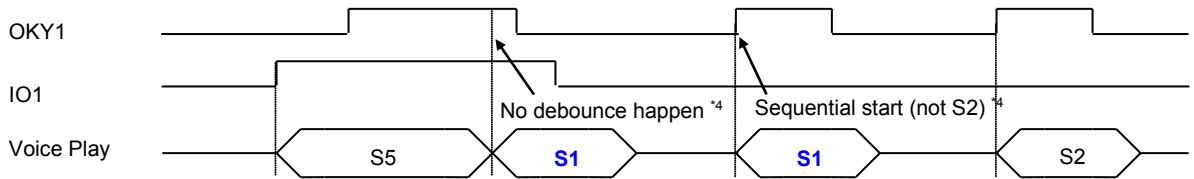

*4: In OKY mode, 1st trigger without debounce and Sequential number is still "1". 2nd trigger with debounce, after trigger the Sequential number become "2".

(b). Random Function

(b-1) OKY1 (L/U/I) =S1 S2 S3 S4, IO1 (L/U/I) =S5

Random (or Sequential) number is counted during "debounce time" or "key released time". But the first-time trigger only relies on "debounce time" due to no "key release time".

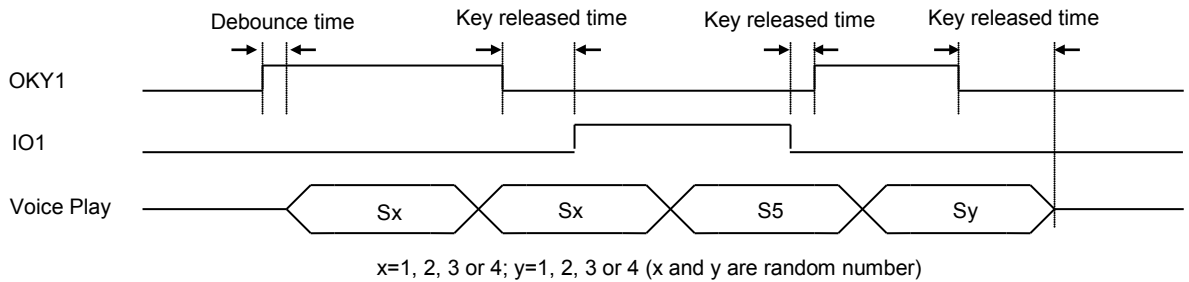

x=1, 2, 3 or 4; y=1, 2, 3 or 4 (x and y are random number)

(b-2) OKY1 (L/U/R) =S1 S2 S3 S4, IO1 (L/U/R) =S16

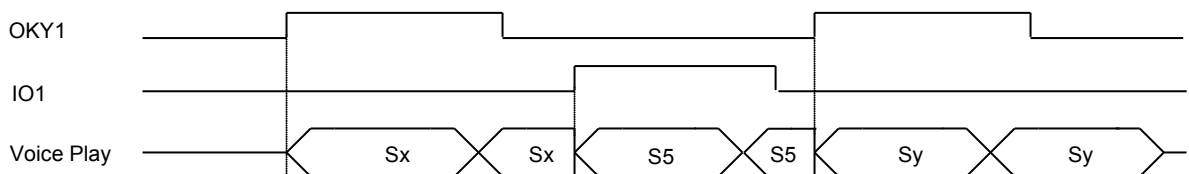

(c). Toggle On/Off Function

(c-1) OKY1 (E/U/R) =S1 S2 S3 S4, IO1 (E/U/R) =S5 (OKY1 is Sequential mode **without Reset**)

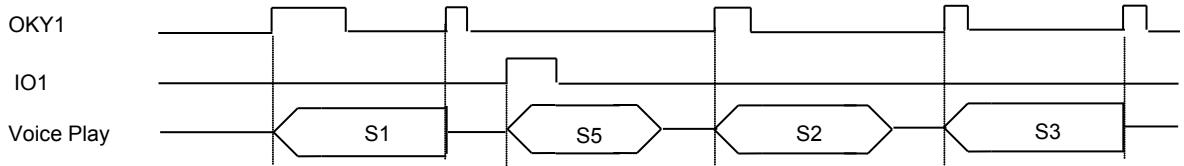

(c-2) OKY1 (E/U/R) =S1 S2 S3 S4, IO1 (E/U/R) =S16 (OKY1 is Sequential mode **with Reset**)

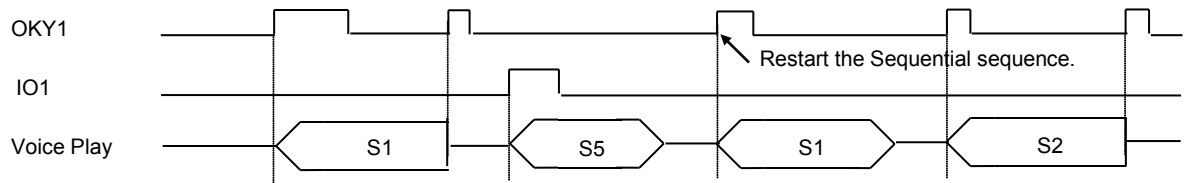

※ When OKY1 Sequential counter is going, to trigger other inputs will reset OKY1 Sequential sequence.

(d). External Feedback Function (IO1 is output and connected to OKY1 input)

(d-1) OKY1 (L/U/I) =S1 S2 S3 S4, IO1=Stop_high pulse (When voice ends, IO1 shows a high pulse.)

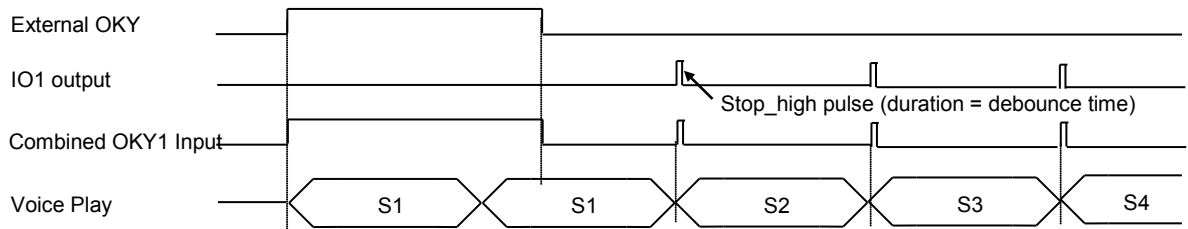

※ Originally the duration of Stop_high pulse is 172ms at 6kHz, but the high signal will trigger voice and turn low after debounce.

(d-2) OKY1 (E/U/I) = S1 S2 S3 S4, IO1= Busy_low (When not playing voice, IO1 is high.)

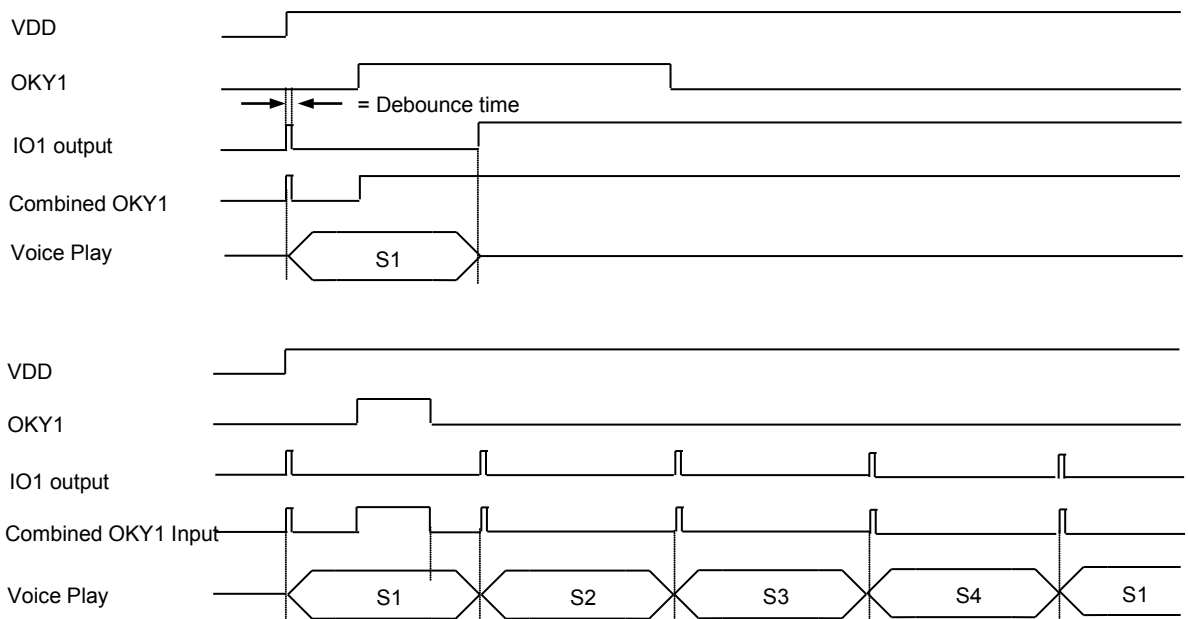

※ When power on, IO1 will generate a high pulse at Busy_low status and the duration is equal to debounce time.

(e). Internal-Feedback Function (OKY1/O5 is fixed as input)

Each sentence can assign an Internal-Feedback Path to play a fixed sentence after IO's sentence stop.

(e-1) OKY1 (L/U/I) = S1 S2 S3 S4, OKY2 = S5, Internal-Feedback Path = OKY1/O5 → OKY2

If S1 is optioned with Internal-Feedback Path,

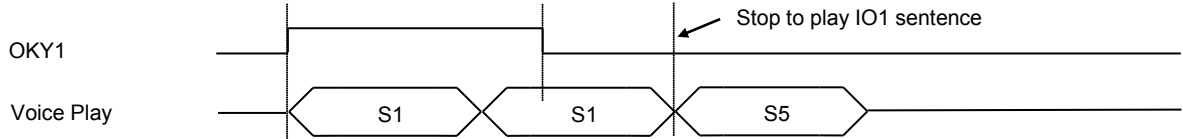

(e-2) OKY1 (L/H/I) = S1 S2 S3 S4, OKY2 (x/x/R) = S5, IO2 (E/U/I) = S6, Internal-Feedback Path = OKY1/O5 → OKY2

If both S1 and S5 are optioned with Internal-Feedback Path,

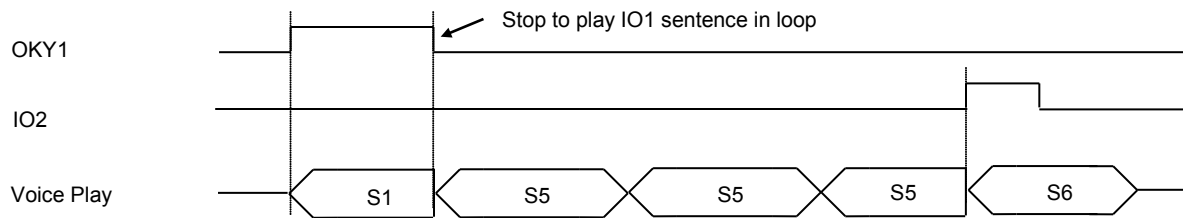

(f). Table-Random Function

When power in on, a random number is counted automatically. The first-time trigger will play the sentence of random number (Sx), and the next trigger will be sequential.

(f-1) OKY1 (E/U/R) = S3 S2 S5 S4 S1 S3 S2 Sx S5 S3 S2 S4 S1 S3 S2 S5 S1 S4 S5 S3 S1 S2

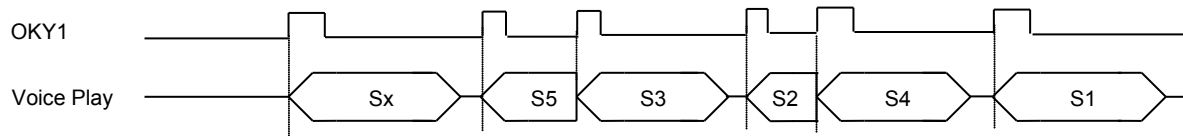

(g). Pause-Resume Function

(g-1) OKY1 (L/U/R) = S1 S2

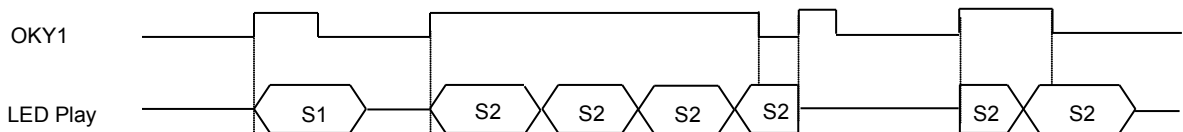

(h). Motor-Recover Function

(h-1) OKY1 (E/U/R) = S1 S2 S3 S4, IO2= Busy_low (OKY1 is Toggle On/Off and OKY2 is connected to sensor.)

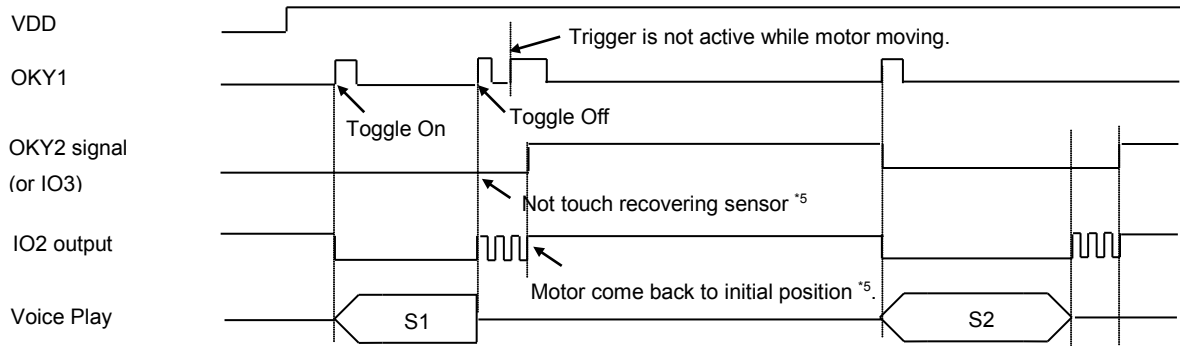

*5: If motor doesn't stop at initial position when voice stop playing, IO2 will output one kind of signal (DC, 15Hz or 30Hz option) to keep motor moving to initial position.

(h-2) OKY1 (E/U/R) = S1 S2 S3 S4, IO2= Busy_low (OKY1 is Toggle On/Off and OKY2 is connected to sensor.)

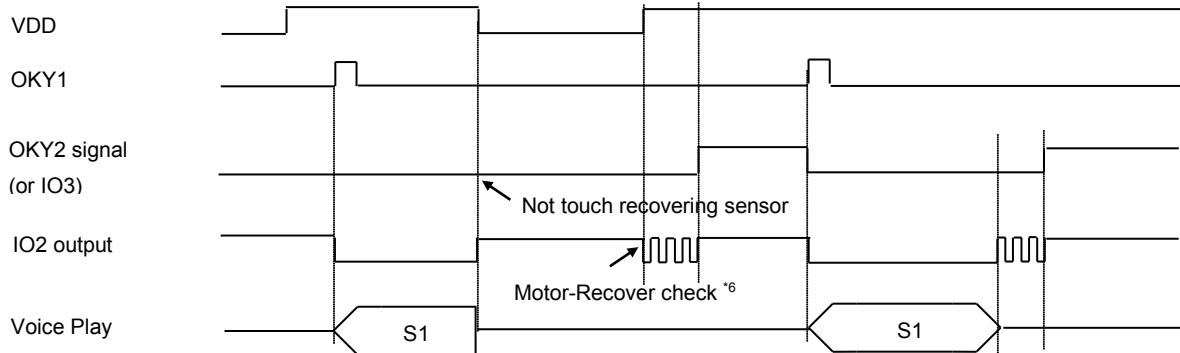

*6: If motor doesn't stay at initial position when power-on, IO2 will output one kind of signal (DC, 15Hz or 30Hz option) to keep motor moving to initial position.

(i). Serial-Trigger Function (All inputs must be set as short debounce)

OKY1 (E/U/R) =S1 S2 S3 S4, IO1 (E/U/R) =S5 (OKY1 Reset is enabled, and S5 is a short mute Sentence)

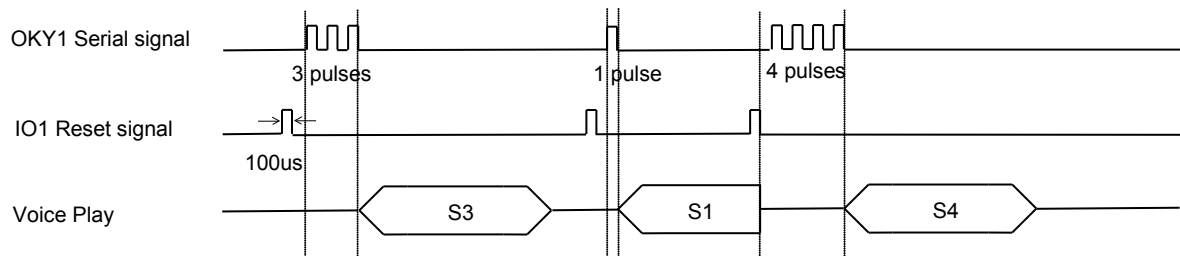

※ The pulse width must be longer than 50us (i.e. short debounce time), and users can set the typical pulse width as 100us.

※ The above is the simplest 2-wire control by external MCU. If necessary, user can use 3-wire control with Busy_High output signal to do feedback.

9. APPLICATION

(1) 1 trigger with 4 LEDs (Sink)

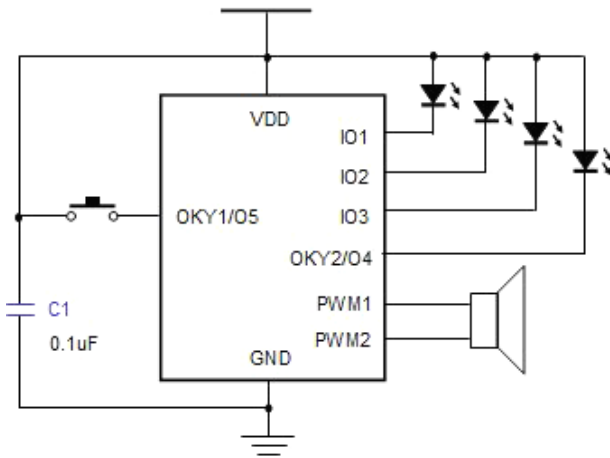

(2) 3 triggers with 2 LEDs (Sink)

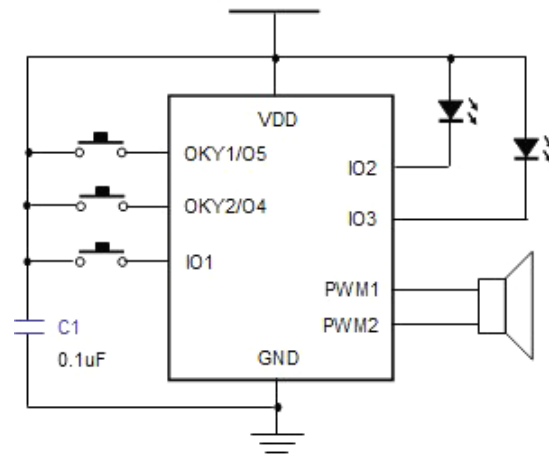

(3) 2 triggers with 2 LEDs (Sink) and 1 motor (Drive)

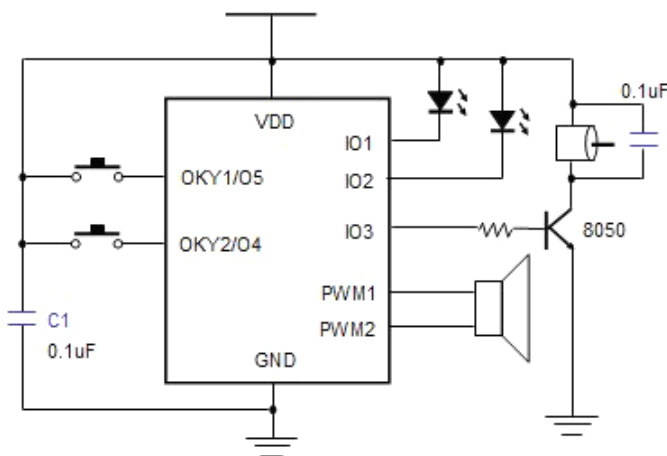

(4) 2 triggers with 2 LEDs (Sink) and 1 motor (Sink)

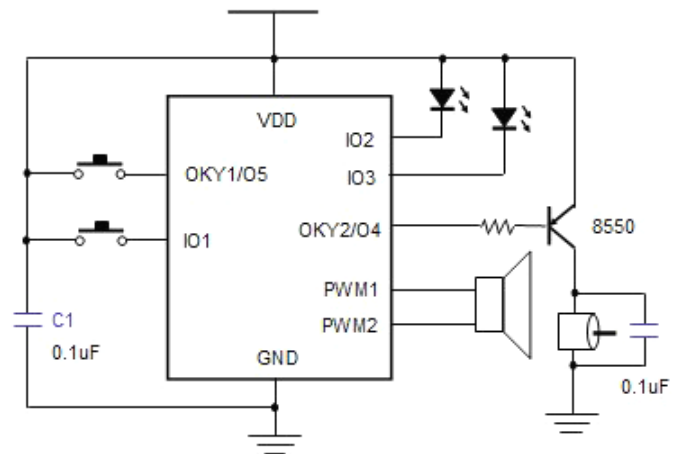

Note: C1 is VDD power cap, please **MUST** connect a 0.1uF cap between VDD and GND, or there will be noise while playing voice.

10. DIE PAD DIAGRAM

NY3P016C, NY3P035C, NY3P065C, NY3P087C, NY3P115C

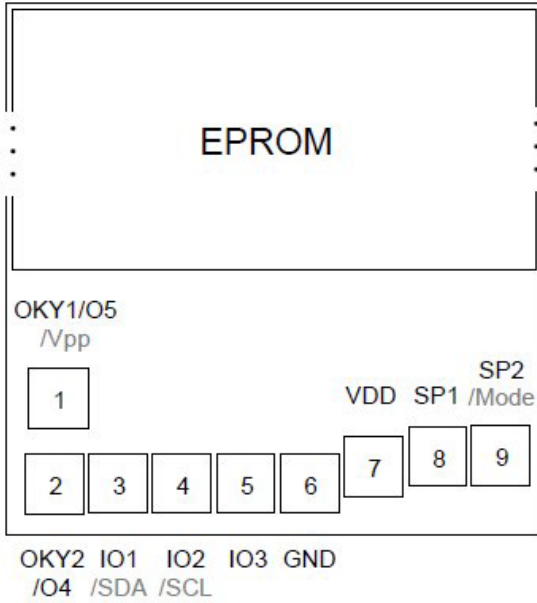

* The IC substrate must be connected to GND or Floating.

11. PACKAGE PIN ASSIGNMENT

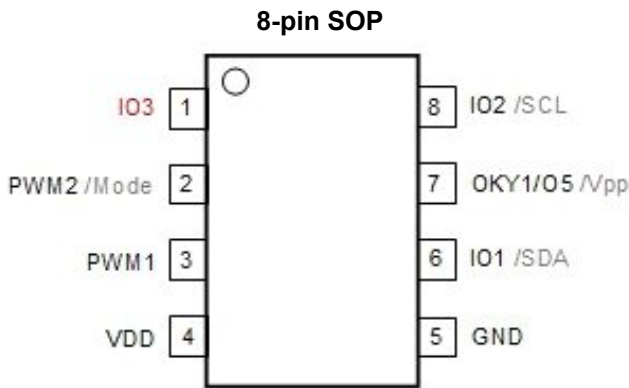

- NY3P016CS8 /**
- NY3P035CS8 /**
- NY3P065CS8 /**
- NY3P087CS8 /**
- NY3P115CS8**

13. PACKAGE DIMENSION

8-Pin Plastic SOP (150 mil)

	INCHES			MILLIMETERS		
	MIN	TYP	MAX	MIN	TYP	MAX
A	0.183	-	0.202	4.65	-	5.13
B	0.144	-	0.163	3.66	-	4.14
C	0.068	-	0.074	1.35	-	1.88
D	0.010	-	0.020	0.25	-	0.51
F	0.015	-	0.035	0.38	-	0.89
G	0.050 BSC			1.27 BSC		
J	0.007	-	0.010	0.19	-	0.25
K	0.005	-	0.010	0.13	-	0.25
L	0.189	-	0.205	4.80	-	5.21
M	-	-	8°	-	-	8°
P	0.228	-	0.244	5.79	-	6.20

Note: For SOP8, 100 pcs per tube & 2.5K pcs per reel.